

Translation of the original operating instructions

EN

OIL CHECK 500

| COMPRESSED AIR QUALITY |



The completeness and accuracy of this documentation have been carefully checked. We reserve the right to make technical changes at any time. These changes may result in deviations from the information provided in this documentation.

The original document was published in the manufacturer's national language (German). All translations are copies of the original document and are only valid in conjunction with the original.

All rights reserved.

© 2025 CS INSTRUMENTS GmbH & Co. KG

Edition and revision status: 10/2025 | V2.01 | 020005723



Table of contents

1	General information	5
1.1	Documentation	5
1.2	Symbols and labels used	5
1.3	Safety instructions and notes	5
2	Security	6
2.1	Intended use	6
2.2	Organizational measures of the operator.....	6
2.3	Residual risks	7
3	OIL CHECK 500	9
3.1	Product overview	9
3.2	Product description	9
3.3	Type plate.....	10
3.4	Scope of delivery.....	10
3.5	Applicable documents	10
4	Transportation and storage	11
4.1	Delivery	11
4.2	Storage.....	11
5	Installation and commissioning	12
5.1	Assemble product	13
5.2	Connect product.....	13
5.3	Initial commissioning	16
5.4	Switching on and off.....	16
6	Operation	17
6.1	Control elements	17
6.2	User interface	17
7	Configuration	18
7.1	Set up basic settings	19
7.2	Activate access protection for menu items	22
7.3	Adjust configuration settings	22
8	Residual oil measurement	24
8.1	Adjust measurement parameters	24
8.1.1	Carry out zero point adjustment.....	24
8.1.2	Adjust gain factor	25
8.1.3	Ensure standard-compliant measurement using heating	25
8.2	Carry out residual oil measurement	27
9	Maintenance and servicing	29
9.1	Maintenance intervals	29
9.2	Clean product.....	29
9.3	Check operating parameters.....	30
9.4	Check cables.....	30
9.5	Check sensor sensitivity.....	31
9.6	Check safety functions	31
9.7	Check mechanical components and connections.....	32



9.8	Check function and wear.....	32
9.9	Perform calibration	32
9.10	Update software	33
9.10.1	Download software package	33
9.10.2	Establish connection	33
9.10.3	Performing a software update	34
9.11	Retrofitting the alarm system	34
9.12	Retrofitting an external heating element	35
9.13	Replace sensor unit	36
9.14	Error states	38
9.14.1	Correct error states	38
9.14.2	Restore factory settings	38
9.15	Customer service	38
10	Decommissioning and disposal	39
11	Appendix	40
11.1	Technical data	40
11.2	Dimensions.....	40
11.3	Spare parts list	41
11.4	Register assignment (incl. error and warning messages).....	41
11.5	Declaration of conformity	43



1 General information

For the sake of simplicity, this documentation refers to the product "OIL CHECK 500" simply as the **product**.

1.1 Documentation

This documentation provides important warnings, safety precautions, and instructions for the safe and proper operation of the product.

- ▷ Before operating the product, read this documentation carefully and ensure that you fully understand its contents.
- ▷ Always keep this documentation readily available for reference purposes.

1.2 Symbols and labels used

The following markings and symbols are used in this documentation:

Labeling/symbol	Usage
Text	Important text passages are highlighted
text	Control elements OIL CHECK 500
Text	Software user interface
Text > Text > Text	User interface click path
2 Security	Cross-reference to text passage, figure or chapter
•	Enumeration, list element
▷	Call to action as part of an instruction. Can also be numbered.
✓	Final or intermediate result of an action instruction
✗	Final or intermediate result of an instruction that has not been achieved
! (in circle)	Note on an intermediate result

Table 1: Symbols and labels used

1.3 Safety instructions and notes

	DANGER Indicates an imminent danger. Death or very serious injuries may result.
	WARNING Indicates a potentially dangerous situation. Death or serious injury may result.
	CAUTION Indicates a potentially dangerous situation. Slight or minor injuries may result.
	NOTICE Indicates a potentially dangerous situation. Material or environmental damage may result.
	NOTE Indicates important information, application tips, and useful information for proper working.



2 Security

The product has been designed, manufactured, and functionally tested in accordance with applicable safety regulations.

To ensure operational safety, please observe the following:

- Chapter "Intended use"
- Chapter "Organizational measures to be taken by the operator"
- Chapter "Residual hazards"

Regardless of the instructions provided in this manual, all applicable country-specific occupational health and safety regulations must be observed.

2.1 Intended use

The operational safety of the product supplied is only guaranteed if it is used as intended.

The product is a high-precision measuring device for monitoring the residual oil content in compressed air systems. It supports compliance with the quality classes defined in ISO 8573-1 through continuous, indicative monitoring of the oil vapor content in accordance with the measuring methods in ISO 8573-5.

Intended use exists in particular if

- the product is operated within the specified pressure range,
- the permissible operating temperature is maintained,
- only gaseous, non-corrosive, non-aggressive carrier gases are used,
- contact with liquids or aerosols is avoided - in particular through suitable pre-filtering,
- the installation is carried out in such a way that condensation in the appliance is excluded (e.g. through adapted temperature control) and
- calibration and maintenance are carried out regularly by qualified personnel.

Any use outside these framework conditions, in particular if the pressure or temperature is exceeded or if liquids or hazardous substances are introduced, is considered improper use and can lead to malfunctions or irreversible damage.

Any use beyond or deviating from this is considered improper use. The manufacturer accepts no liability for any resulting damage.

Intended use also includes:

- Adherence to the supplied documentation
- Compliance with all inspection and maintenance requirements specified by the manufacturer

Reasonably foreseeable misuse or improper handling are:

- Contact with liquids
- Contact with steam, aggressive gases or hazardous substances
- Use as a climbing aid
- Operation outside the technical specifications
- Tampering with the product in any way that does not comply with the intended and described procedures
- Continuous outdoor operation in wet conditions or direct exposure to the weather
- Use in potentially explosive atmospheres

2.2 Organizational measures of the operator

The product may only be used if it is in perfect technical condition. It may no longer be used if it has been technically modified or damaged.



Instructions

The information on commissioning, operation, and maintenance provided in these instructions must be followed. These instructions should always be kept accessible with the product.

Personnel

People working on the product must read these instructions, particularly the chapter entitled " 2 Security", before starting work. This also applies to people who only work occasionally.

2.3 Residual risks



DANGER

Risk of injury due to insufficiently qualified personnel

Improper handling of the product can lead to serious personal injury and damage to property. All work described in these instructions may only be carried out by qualified specialists.

Qualified personnel are persons with appropriate training and in-depth knowledge of measurement, control, regulation and compressed air technology. They must also be familiar with the applicable national regulations, standards and directives and be able to assess risks independently.



DANGER

Injury or death from touching live parts

When carrying out installation and maintenance work, you may encounter parts that carry dangerous voltages during operation. Touching live parts can lead to death.

- ▷ Work on electrical systems or equipment may only be carried out by qualified electricians or by instructed persons under the direction and supervision of a qualified electrician in accordance with electrotechnical regulations.



DANGER

Danger from escaping compressed gas

Contact with escaping pressurized gas or unsecured system parts can lead to serious injury or death.

- ▷ Only carry out installation and maintenance work when the system is depressurized.
- ▷ Only use pressure-resistant installation material and suitable tools that are in perfect working order.
- ▷ Before pressurizing, check all system parts and tighten all screw connections.
- ▷ Always open valves slowly to avoid pressure surges.
- ▷ Install compressed air lines tightly.
- ▷ Ensure that people and objects cannot come into contact with escaping compressed gas.
- ▷ Avoid transmitting vibrations, oscillations and shocks to the product.
- ▷ Carry out a leak test of the system before commissioning.



WARNING

Danger due to improper power supply or modifications

The product is designed for a safe low voltage of +24 V DC (Extra Low Voltage). The touch voltage is well below life-threatening limits for adults and normal applications.

- ▷ Always ensure that the power supply unit complies with the specifications. Proper functioning and the integrity of the power supply unit must be ensured. In the event of unusual heating, the power supply unit must be checked, repaired or replaced immediately by a specialist.
- ▷ Do not use mains voltage or higher voltages. Modifications, installations or attachments with higher voltages - especially mains voltage - are at your own risk. In such cases, the operator bears full responsibility for electrical safety.

**WARNING****Danger during operation outside the specified limit values**

Exceeding or falling below the permissible operating, storage or transportation limits can endanger people and property. There is a risk of malfunctions and operating faults as well as falsified measurement results.

- ▷ Only operate the product within the limit values specified on the rating plate and in the technical data.
- ▷ Observe the permissible storage and transportation conditions.

**WARNING****Danger due to exceeding pressure or temperature limits or fire**

Exceeding the permissible operating pressures or operating temperatures can lead to serious damage to the appliance or danger to persons. The operator is responsible for protecting the system against excess pressure and temperature - especially in the event of possible sources of fire at the installation site.

Safety devices to protect against excess pressure due to fire are not included in the scope of delivery.

- ▷ Ensure that the permissible operating limits are not exceeded under any circumstances.
- ▷ Take suitable measures to ensure that the ambient conditions at the installation site remain within the permissible operating temperatures.
- ▷ Check whether there are potential sources of fire at the installation site and, if necessary, take additional protective measures to prevent excess pressure due to fire.

**CAUTION****Danger due to malfunction of the product**

Incorrect installation or inadequate maintenance can lead to malfunctions that impair the function of the product and can lead to dangerous misinterpretations.

- ▷ Observe all applicable national regulations and safety regulations during installation and operation.

**WARNING****Risk of injury due to unauthorized modifications**

Unauthorized device modifications can cause injuries and lead to the loss of the operating permit. Operation is only permitted with original components.

- ▷ Unauthorized modifications are not permitted and lead to the exclusion of any warranty and liability by the manufacturer (CS INSTRUMENTS).

3 OIL CHECK 500

3.1 Product overview

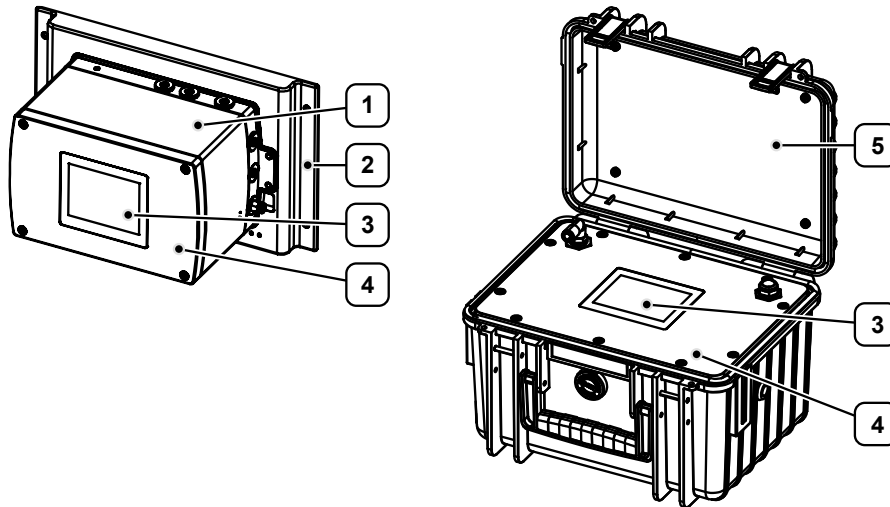

Figure 1: OIL CHECK 500 (example)

- | | | | |
|---|------------------------------|---|-----------------------|
| 1 | Stationary appliance variant | 4 | Housing cover |
| 2 | Heating element (optional) | 5 | Mobile device variant |
| 3 | Touch screen | | |

3.2 Product description

The product is a highly sensitive measuring system for the early detection of potential contamination in compressed air systems.

Precise monitoring of critical parameters such as pressure dew point and, in particular, residual oil content is essential to ensure consistently high compressed air quality. The system continuously takes a sample directly from the compressed gas flow - without additional fittings - and analyzes it in real time for traces of organic compounds. The "Forced Pressure Variation" process enables automatic tracking of the sensor signal directly in field operation if required.

Key features

- Non-specific monitoring for a variety of organic and inorganic components that meet the "oil vapor" criterion or are known as indicator molecules for oil vapors.
- Online measurement of the oil vapor content according to the test methods of ISO 8573-5. The display is in mg/standard m³ (standard conditions: 1.0 bar abs., +20 °C, 0 % r. h.).
- Specially developed for use between laboratory analyses to ensure long-term operational safety.
- Detects deviations at an early stage and provides targeted warnings in the event of impending contamination - without false positive alarms.

The product contains the following actively controlled components:

- Solenoid valve I (inlet side)
- Solenoid valve II between dosing chamber and measuring chamber
- Solenoid valve III (outlet side)
- Vacuum diaphragm pump
- Absolute pressure sensor
- Photoionization detector (PID sensor)
- Humidity sensor for measuring the internal humidity and gas temperature

The solenoid valves are open when de-energized. If the power supply is interrupted, the dosing and measuring chambers are automatically purged. If there is no inlet overpressure, both chambers are open to the environment, which enables diffusion-based gas exchange.

Data transmission

The measured values are output both digitally and analogly at the corresponding interfaces. In addition to the standard mode, a mobile mode (mobile measuring channel) is available for both device variants, which enables a faster response of the oil vapor display. In mobile mode, the measured values are not smoothed to a greater extent.

Measuring channel	Sampling rate	Intended use	Note
Standard mode	0.1 Hz	Long-term sampling	Factory setting for stationary device variant
Mobile mode	1 Hz	For fast response with higher interval and shorter response time (reduced resolution)	Factory setting for mobile device variant

Table 2: Overview of measuring channels

3.3 Type plate



Figure 2: Type plate (example)

- | | | | |
|---|----------------------------------|---|------------------------|
| 1 | Manufacturer information | 5 | Available options |
| 2 | Technical data | 6 | Material/serial number |
| 3 | Conformity/certification marking | 7 | Product designation |
| 4 | Electrical connection data | | |

3.4 Scope of delivery

The scope of delivery includes the following components:

- OIL CHECK 500
- Plug-in power supply unit (24 V DC)
- PTFE connection tube (outer diameter 6 mm)
- Calibration certificate
- USB storage medium
- Translation of the original operating instructions

Optionally additionally required:

- Mounting accessories (e.g. screws and dowels)
- Reductions or transitions for installation in existing compressed air lines
- Electrical accessories for connection to higher-level systems or data loggers

3.5 Applicable documents

This Translation of the original operating instructions contains information on the operation of the product "OIL CHECK 500". This essentially includes information such as

- Installation and commissioning
- Residual oil measurement
- Maintenance and servicing



4 Transportation and storage

**NOTE**

Improper transportation, storage and commissioning are accident-prone and can cause damage or malfunctions to the delivered product, for which the manufacturer (CS INSTRUMENTS) does not grant any liability or warranty.

4.1 Delivery

Transport damage

- ▷ Check the delivered components for any visible transportation damage.
- ▷ Report any transportation damage to the following parties immediately:
 - the carrier
 - the manufacturer's customer service (CS INSTRUMENTS)
- ▷ Ensure that the product is handled properly during transportation.

Packaging

- ▷ Keep the original packaging for any future transportation or storage.

4.2 Storage

To avoid damage due to environmental influences, the product must be stored properly when not in use.

- ▷ If possible, store the product in its original packaging.
- ▷ Store the product in dry, dust-free rooms.
- ▷ Keep the product away from direct sunlight, heat sources, and corrosive or aggressive chemicals.

5 Installation and commissioning



WARNING

Damage to the product

In order to capture oil vapors in accordance with ISO 8573-5, an upstream filter for separating aerosols and liquids is **essential**.

- ▷ Install a suitable filter upstream of the product to reliably remove aerosols and liquid components from the medium. This is the only way to ensure accurate and long-term trouble-free measurement.



CAUTION

Danger from commissioning a damaged product

If a damaged product is installed or put into operation, it may result in functional failures, electrical hazards, or mechanical risks.

- ▷ Before each start-up, inspect the product, accessories, and all supply lines for visible damage, loose parts, or missing components.
- ▷ Immediately take any defective product out of operation immediately.



CAUTION

Observe the process connection

To ensure safe and reliable operation of the product, the following points must be observed when connecting the process:

- ▷ **Choice of material:** Use stainless steel piping or PTFE tubing for the connection.
- ▷ **Ease of maintenance:** Install an oil and grease-free shut-off valve between the product and the process to facilitate maintenance work.
- ▷ **Mounting position:** Avoid mounting below the measuring point, as liquid media could penetrate the device and damage it in the event of a malfunction.
- ▷ **Product protection:** Avoid unprotected installation, as liquid or solid impurities can be deposited in the product and permanently impair the measuring accuracy.



5.1 Assemble product

Installing the product (stationary appliance version)

Proceed as follows to install the stationary device variant correctly.

- ▷ Mount the product vertically on the wall using suitable wall plugs and screws.
 - ⓘ The wall mounting must be designed for a load of at least 10 kg.
- ▷ Observe the corresponding drilling pattern.
- ▷ Tighten the screws with a tightening torque suitable for the surface.
 - ⓘ Ensure that the torque is suitable for the substrate and anchor type so that the connection is tight without overtightening the anchor or damaging the substrate.

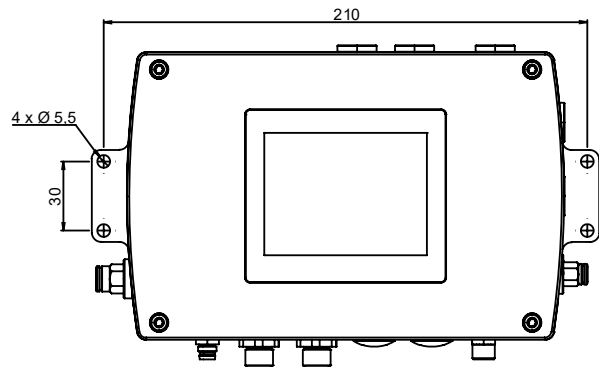

Figure 3: Drilling pattern without heating element

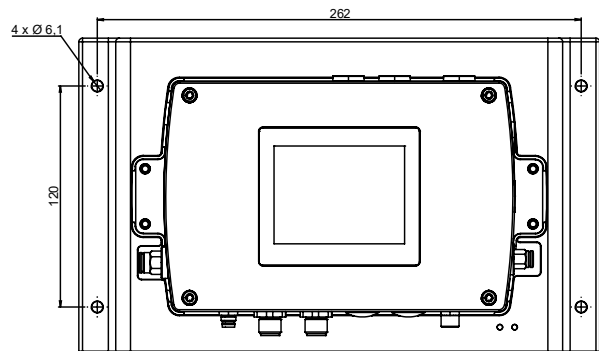

Figure 4: Drilling pattern with external heating element

Installing the product (mobile device variant)

The mobile device variant is permanently integrated in the transport case and only requires the system connection at the installation site.

- ▷ Further information can be found in chapter "[5.2 Connect product](#)".

5.2 Connect product



DANGER

Danger to life due to electrical voltage

During installation, maintenance or in the event of a fault, touchable conductive parts can carry dangerous voltages. Contact with uninsulated parts or mains voltage can lead to serious injury or death.

- ▷ Do not operate the product if power supply cables are damaged or housing parts are defective or removed.
- ▷ Strictly observe all locally applicable regulations and safety regulations.
- ▷ Only carry out work on electrical connections when the power supply is switched off. Secure the product against unintentional restarting.
- ▷ Check all electrical connections before commissioning and regularly during operation.



DANGER

Injury or death from touching live parts

When carrying out installation and maintenance work, you may encounter parts that carry dangerous voltages during operation. Touching live parts can lead to death.

- ▷ Work on electrical systems or equipment may only be carried out by qualified electricians or by instructed persons under the direction and supervision of a qualified electrician in accordance with electrotechnical regulations.

Connecting the product pneumatically (stationary device variant)**WARNING****Damage to the product**

To prevent leaks or malfunctions, all factory-fitted blanking plugs must be removed before commissioning.

- ▷ Remove all factory-fitted blanking plugs.

**CAUTION****Representative sampling for oil content measurement**

Representative sampling is essential for accurate oil content measurement. The sampling point must be selected in such a way that a usable mixture of all compressed air components is recorded.

In the case of gaseous and vaporous organic compounds, a homogeneous distribution in the measurement cross-section can generally be assumed. In such cases, sampling at a fixed point, ideally centrally in the measuring cross-section, is recommended.

The compressed air connection (G 1/4" internal thread, ISO 228-1) is located on the side of the housing for the stationary device variant and in the housing cover for the mobile variant.

Materials

- Mobile sampling system: 2 m PTFE hose with quick coupling **or**
- Permanently installed sampling system: 1/2" ball valve, 1 m stainless steel tube (6x1 mm) with cutting ring fitting

- ▷ Check that the nominal pressure and media purity correspond to the product specifications.
- ▷ Establish the connection between the compressed air line and the compressed air connection of the product.
 - ⓘ Only use suitable hoses and connections that are designed for the operating pressure and the medium.
 - ⓘ Ensure that the connection components are free of oil and grease.
- ▷ Seal the pipe connections with suitable sealing rings.
- ▷ Ensure that all screw connections are firmly tightened.
- ▷ Carry out a leakage test on the entire installation.
- ▷ Measure the flow rate.
 - ⓘ Further information can be found in chapter "8.2 Carry out residual oil measurement".

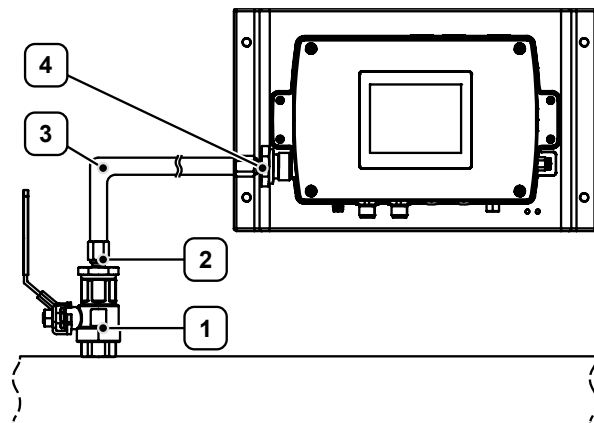
**Figure 5: Connecting the product (example)**

- | | | | |
|---|-------------------------------|---|-------------------------------|
| 1 | Ball valve (G 1/2") | 3 | Stainless steel pipe (6x1 mm) |
| 2 | Cutting ring fitting (G 1/2") | 4 | Cutting ring fitting (R1/4") |



Connecting the product electrically

All connections required for operation are located on the side of the housing.

Materials

- Supplied power supply unit (mains cable included in the scope of delivery) **or**
- External +24 V DC supply (to be provided by the customer)

- ▷ Ensure that the product is fully assembled and has no visible damage.
- ▷ Check whether the mains voltage specified on the power supply unit matches the local mains voltage (only for operation with power supply unit).
- ▷ Connect the mains cable of the supplied power supply unit to the connection socket provided on the product **or** connect the 24 V DC supply cable.
- ▷ Connect the other end of the mains cable to a suitable socket or connect the 24 V cable to the corresponding voltage source.
- ▷ Fit the cable ends to be connected with wire end ferrules.
- ▷ Connect the functional earthing in accordance with the applicable regulations.
- ▷ Connect all necessary electrical connections to the product.
- ▷ Observe the country-specific regulations on electrical safety.

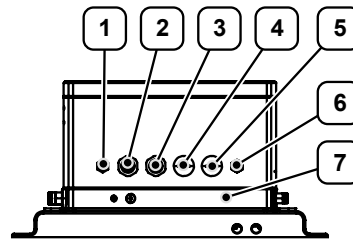

Figure 6: Connecting the product (example)

- | | | | |
|---|--|---|---|
| 1 | Power supply | 5 | Alarm |
| 2 | Modbus RTU data recorder / process control | 6 | Power supply (optional heating element) |
| 3 | Service/diagnostic interface | 7 | Functional earthing |
| 4 | 4-20 mA output 1 and 2 | | |

Designation	Plug type	Assignment	Plug
1 PWR A Power supply	M8 (M) ¹	Pin 1 (24 V DC) Pin 3 (GND)	
2 RS485 Modbus RTU data recorder / process control	M12 (M)	Pin 1 (Vin_Detect) Pin 2 (Modbus A) Pin 3 (GND) Pin 4 (Modbus B) Pin 5 x	
3 RS485 Service/diagnostic interface	M12 (M)	Pin 2 (Modbus A) Pin 3 (GND) Pin 4 (Modbus B)	
4 4...20mA 4-20 mA output 1 and 2 ²	M12 (M)	Pin 1 X Pin 2 (4-20 mA -2nd) Pin 3 (4-20 mA -) Pin 4 (4-20 mA +2nd) Pin 5 (4-20 mA +)	
5 Alarm (external signal processing) (max. 60 V + max. 150 mA)	M12 (M)	Pin 1 (Alarm 1) Pin 2 (Alarm 1) Pin 3 (GND) Pin 4 (Alarm 2) Pin 5 (Alarm 2)	

¹ M = Male (pin contacts), F = Female (socket contacts)

² output 2 optional



Designation	Plug type	Assignment	Plug
6 PWR B Power supply (optional heating element)	M8 (F)	Pin 1 (24 V DC_Out) Pin 2 (Modbus A) Pin 3 (GND) Pin 4 (Modbus B)	

Table 3: Pin assignment | stationary device variant

Designation	Connector type	Pin assignment	Connector
RS485 (service and diagnostic interface)	M12 (M)	Pin 2 (Modbus A) Pin 3 (GND) Pin 4 (Modbus B)	
Plug connector	Push-pull circular connector (F)	Pin 1 (+ RS485) Pin 2 (- RS485) Pin 4 (Analog IN +) Pin 5 (Analog IN -) Pin 8 (GND)	

Table 4: Pin assignment | mobile device variant

5.3 Initial commissioning



CAUTION

Impaired EMC and overvoltage safety due to missing functional earthing

Without correct functional earthing, neither electromagnetic compatibility nor protection of the device against overvoltages is guaranteed.

- ▷ Establish the functional earthing in accordance with the applicable regulations before the product is put into operation.



CAUTION

Temperature equalization before commissioning

Strong temperature fluctuations, e.g. due to transportation or storage, can damage the product or lead to incorrect measured values.

- ▷ Ensure that the device has reached the ambient temperature, especially after storage below 20 °C.
- ▷ Do not put the product into operation until the temperature has completely equalized.

Putting the product into operation

- ▷ Connect the product to the power supply.
- ▷ After switching on, wait until the measured value is stable.
 - ⓘ After connecting, it may take longer for the pipework and measuring chamber to be completely flushed.
 - ⓘ Depending on the type of system and storage conditions, this may take up to 24 hours.

5.4 Switching on and off

Switching on

- ▷ Connect the product to the power supply.
 - ✓ As soon as measurement results appear, the measuring device is ready for operation.
 - ⓘ A measured value is usually displayed after a few seconds to minutes.

Switching off

- ▷ Disconnect the product from the power supply.
 - ✓ The device switches itself off.



6 Operation

6.1 Control elements

CAUTION

Damage to the touchscreen

▷ Do not use pens or other sharp-edged objects to operate the touchscreen.

Touch screen

The user interface is operated via the touchscreen.

- ▷ Select menu items by tapping them with your finger or a soft, round stylus.

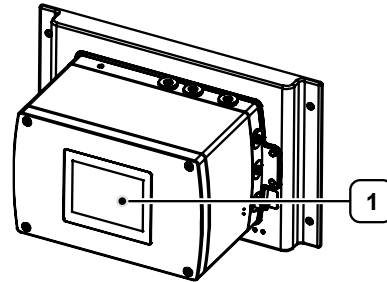

Figure 7: Operating elements (example)

- 1 Touch screen

6.2 User interface

The following user interface is displayed each time the product is started.

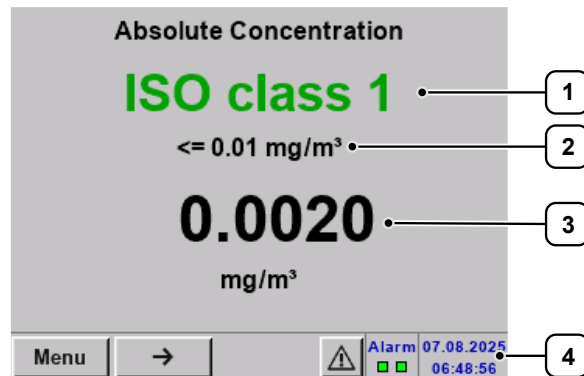

Figure 8: User interface | Main view (example)

- | | |
|--|--|
| <ul style="list-style-type: none"> 1 Air class 2 Concentration range | <ul style="list-style-type: none"> 3 Measured value 4 Status bar |
|--|--|

Status bar

Various information is displayed in the status bar:

- Diagnostic information: As soon as the warning symbol is displayed in color, diagnostic information is available.
- Switching status of the alarm relays: The two green and red squares indicate the current switching status of the alarm relays.
- Real-time clock: A battery-buffered real-time clock displays the current date and time.

7 Configuration

Open main menu

The main menu is the starting point for all central functions of the product.

- ▷ Tap the Menu button.
 - ✓ The main menu opens.
 - ⓘ The menu items in the left-hand area are freely accessible and do not affect the measured values.
 - ⓘ The menu items in the right-hand area (sensor settings, expert settings, password and device settings) can be protected by a password. Further information can be found in chapter "[7.2 Activate access protection for menu items](#)".

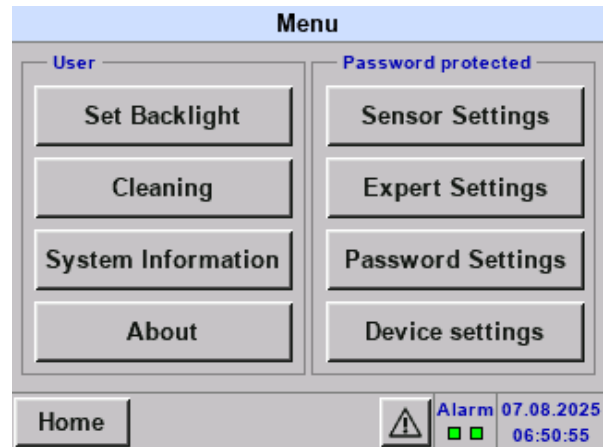



Figure 9: Open main menu (example)

Setting the display brightness and standby mode

A reduced screen brightness value and a short screen switch-off time help to minimize energy consumption.



NOTICE
Burn-in of the display
High, continuous display brightness can cause the display to burn in, among other things. Dimming the display helps to reduce this risk.

- ▷ Tap the Lighting button.
- ▷ Select the desired settings.



Figure 10: Setting the display brightness and standby mode (example)



7.1 Set up basic settings

Open device settings

- ▷ Tap the **Device settings** button.
 - ⓘ The **Engineering** menu item contains special functions for device service. These are primarily intended for maintenance, diagnostics and advanced settings and should only be used by qualified specialists.

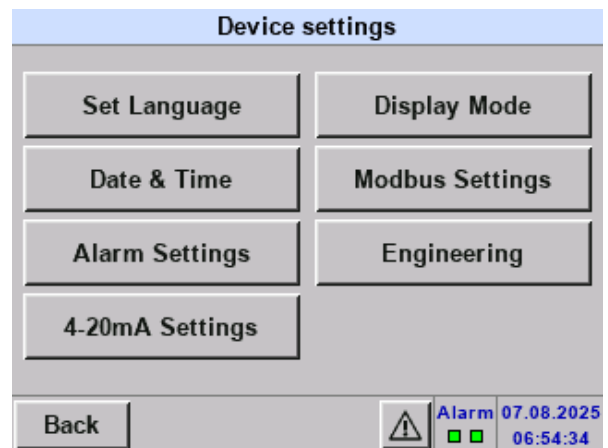

Figure 11: Open device settings (example)

Set language

German and English are currently available as language settings.

- ▷ Tap the **Set language** button.
- ▷ Select the desired settings.

Set date and time

- ▷ Tap the **Date & time** button.
- ▷ Select the desired settings.

Set alarm (stationary device variant)

The alarm values for the visual and audible alarm can be freely set.

- ▷ Tap the **Alarm settings** button.
- ▷ Activate the desired alarm (**Optical Alarm** / **Acoustic Alarm**) using the corresponding checkbox.
- ▷ Select the desired settings.
- ▷ Tap the **Default** button, to restore the factory settings.

Alarm1 - Optical Alarm		
Source	Oil Vapor	
Threshold	0.100	mg/m ³
Hysteresis	0.0020	mg/m ³
Output Polarity	Normally Close	
Default		
OK Cancel		

Figure 12: Factory settings for visual alarm

Alarm2 - Acoustic Alarm		
Source	Oil Vapor	
Threshold	0.100	mg/m ³
Hysteresis	0.0020	mg/m ³
Output Polarity	Normally Close	
Default		
OK Cancel		

Figure 13: Factory settings for audible alarm

**NOTE**

To install an alarm device retrospectively, see chapter "→ 9.11 Retrofitting the alarm system".

Configuring the analog output

The measuring range of the analog output (4-20 mA) is freely configurable.

- ▷ Tap the **4-20mA settings** button.
- ▷ Activate the desired channel (**4-20mA Ch1** / **4-20mA Ch2¹**) using the corresponding checkbox.
- ▷ Select the desired settings.
- ▷ Tap the **Default** button, to restore the factory settings.

4-20mA Channel 1		
Source	Oil Vapor	
4mA:	0.000	mg/m ³
20mA	5.000	mg/m ³
Error Current	stay at terminal value	
Default		
OK Cancel		
Alarm ■ ■ 07.08.2025 06:57:31		

Figure 14: Configuring the analog output (example)

¹ output 2 optional for stationary device variant



Setting the display mode

The mobile measuring channel can be activated via the Display mode menu item. In addition, the measuring unit can be changed from mg/m³ to ppm and other unit settings can be adjusted.

- ▷ Tap the Display mode button.
- ▷ Select the desired settings.

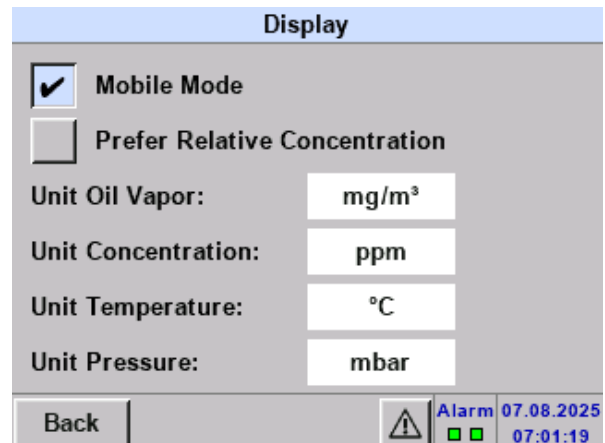

Figure 15: Set display mode (example)

Set Modbus data transmission

The settings for Modbus data transmission can be made via the Modbus settings menu item.

Two RS485 connections are available as standard:

- Modbus [2]: Modbus RTU data recorder / process control
- Modbus Diag [3]: Service/diagnostic interface

- ▷ Tap the Modbus settings button.
- ▷ Select the desired settings.
- ▷ Tap the Default button, to restore the factory settings.

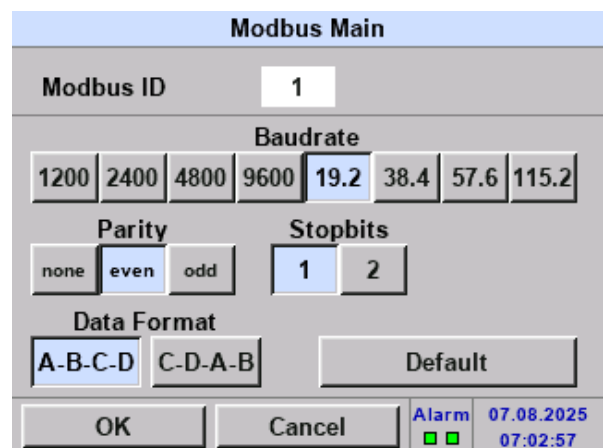

Figure 16: Factory settings Modbus RTU data recorder / process control

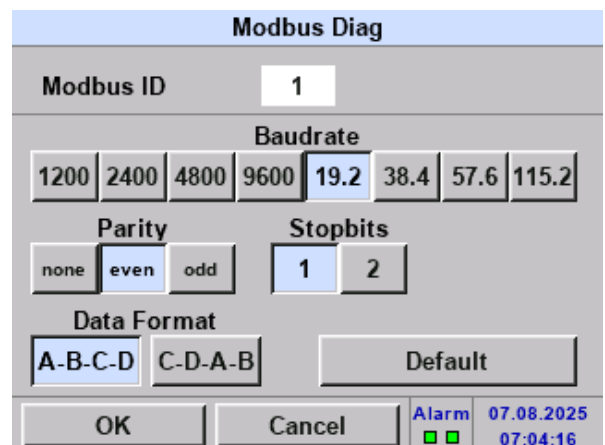

Figure 17: Factory settings Service/diagnostic interface

7.2 Activate access protection for menu items

Activate access protection for menu items

The menu items Sensor settings, Expert settings, Password and Device settings can be password-protected against unauthorized access.

- ▷ Tap the Password button.
- ▷ Enter the desired password.
 - ⓘ The password must be a four-digit numeric code.
 - ⓘ If "0000" is set as the password, the password prompt is omitted when opening protected menu items. This effectively removes access protection for the relevant areas.
- ▷ Repeat the entry for confirmation.
- ▷ Make a note of the password in a safe place.
 - ⓘ **If you lose it:** Contact customer service to reset the password.



Figure 18: Enter new password (example)

7.3 Adjust configuration settings



CAUTION

Danger due to incorrect calibration

Improper adjustment of the parameters can lead to considerable deviations in the measured values.

- ▷ Parameters may only be adjusted by qualified specialists with expert knowledge of the system and the monitored gases.

Open sensor settings

- ▷ Tap the Sensor settings button.
 - ✓ The menu for configuring the sensor settings opens.

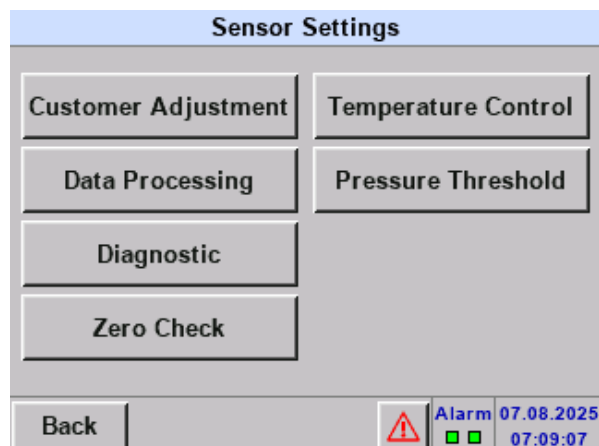

Figure 19: Set sensor parameters (example)



Select operating mode

You can choose between two operating modes:

- Vapor Standard Mode: ISO-compliant measurement mode for typical applications
- Vapor Analysis Mode: Highly sensitive mode for detailed analyses and detection limit optimization

- ▷ Tap the Data Processing button.
- ▷ Select the desired settings.
 - ⓘ The Response speed parameter controls the signal smoothing. Higher values lead to a smoother curve, but reduce the response speed of the system.

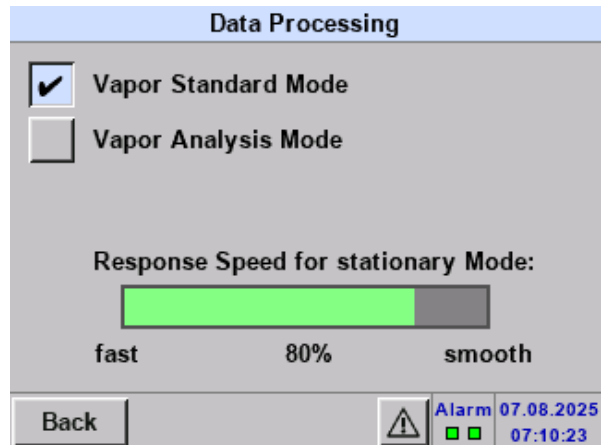

Figure 20: Select operating mode (example)

Activate self-check and system pressure measurement at system startup

An automatic self-check and cyclical diagnostics can be activated at the specified time interval (hh:mm) when the system is started.

- ▷ Tap the Diagnostics button.
- ▷ Select the desired settings.
 - ⓘ If "0:00" is set as the cycle time, the cyclical diagnostics function is deactivated.

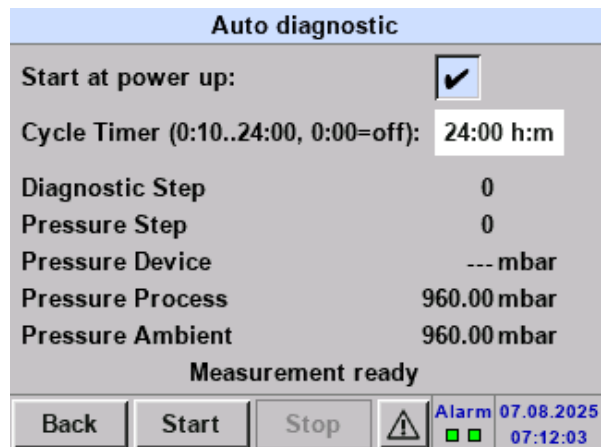

Figure 21: Configure self-check at system start (example)

8 Residual oil measurement

8.1 Adjust measurement parameters

Each measuring device is subjected to an extensive calibration procedure before delivery. This involves coordination and verification with certified reference systems across several concentration levels.

If necessary, a readjustment can be made for the place of use. This adjustment can be reversed at any time by resetting to the factory settings.

Further information can be found in chapter " 9.14.2 Restore factory settings".



CAUTION

Danger due to incorrect calibration

Improper adjustment of the parameters can lead to considerable deviations in the measured values.

- ▷ Parameters may only be adjusted by qualified specialists with expert knowledge of the system and the monitored gases.



NOTE

If the measured values need to be updated at short intervals of a few days, it is recommended to maintain the product and its process coupling and to subject the gas or compressed air used to a laboratory analysis.

Open sensor settings

- ▷ Tap the Sensor settings button.
 - ✓ The menu for configuring the sensor settings opens.

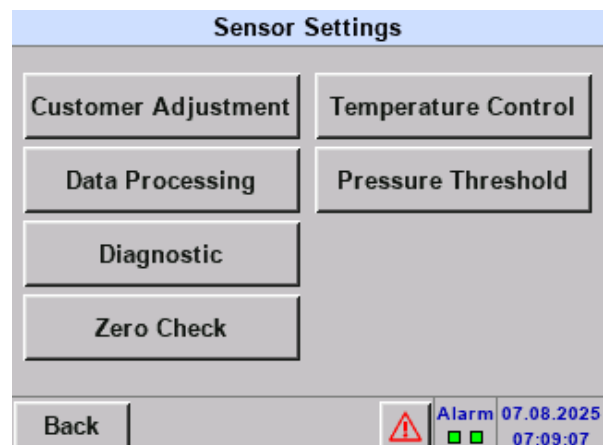

Figure 22: Set sensor parameters (example)

8.1.1 Carry out zero point adjustment

Zero point determination via forced pressure variation

With the "Forced Pressure Variation" method, the zero point of the sensor can be set during the ongoing measurement - without filters and without additional devices. First, a negative pressure of approx. 500 mbar (absolute) is generated in the temperature-stabilized measuring chamber. The chamber is then filled with the connected, homogeneous pure gas to 1000 mbar and then to 1500 mbar.

The number of molecules in the measuring chamber is varied via defined pressure changes in order to check a correlation with the raw signal of the sensor.



NOTE

If the sensor signal remains constant when the output pressure is doubled or tripled, a zero point adjustment is permitted.



- ▷ Tap the **Zero adjustment** button.
- ▷ Tap the **Start** button.
 - ✓ If no oil vapor is detected, the determined offset (relative to the factory calibration) can be saved.
 - ⓘ Bar graph display: 500 mbar = reference value; 1000 mbar = 2 x pressure; 1500 mbar = 3 x pressure
- ▷ Tap the **Save** button.
 - ✓ The new zero point is saved in the system.

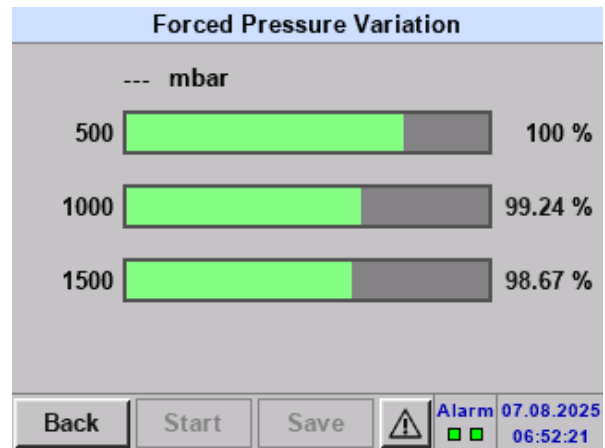

Figure 23: Perform zero point adjustment (example)

8.1.2 Adjust gain factor

Adjusting the amplification factor

When analyzing gas mixtures, it may be necessary to relate the measured signal value to a single target gas. In such cases, an amplification factor (response factor) is used. This has a multiplicative effect on the measured value and corrects the influence of inactive gas components within the mixture.

- ▷ Tap the **User adjustments** button.
- ▷ Enter the desired amplification factor in the **Response factor** field.

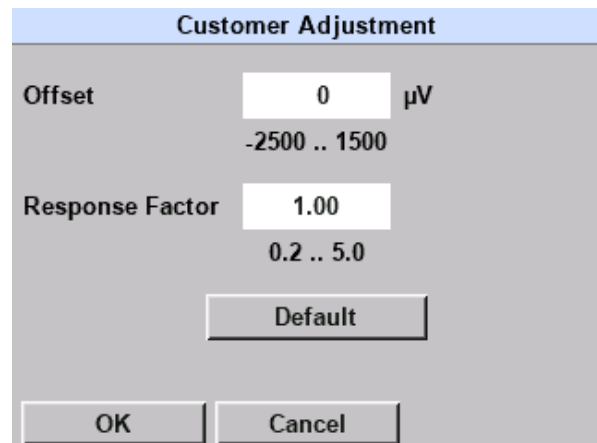

Figure 24: Adjust amplification factor (example)



NOTICE

Typical application example

In a gas mixture of 50% helium and 50% nitrogen, in which only helium is to be analyzed for residual oil, only half of the helium is present. In order to compensate the measured value correctly, the response factor must be set to "2".

8.1.3 Ensure standard-compliant measurement using heating

The product has precise temperature control (accuracy ± 0.6 °C) for stable measuring conditions. At low ambient temperatures, the system actively heats the interior, e.g. from 10 °C to over 20 °C, thus ensuring standard-compliant, reliable measurement.

- Stationary device variant: external heating element (**optionally** available)
- Mobile device variant: integrated heater for quick adjustment after transportation in a cold environment (standard)

Configure temperature control (stationary device variant)



NOTICE

Limit of the heating effect of the external heating element

The external heating element can regulate the internal temperature by up to +15 °C above or -5 °C below the ambient temperature.

- ▷ For retrofitting: Connect the heating element.
 - ⓘ Further information can be found in chapter "→ 9.12 Retrofitting an external heating element".
- ▷ Tap the **Temperature control** button.
- ▷ Check the box next to **Connected** to establish the connection to the device.
- ▷ Check the **Enabled** box to switch the heating element on.
- ▷ Enter the desired target temperature.
 - ⓘ For a stable measuring environment, we recommend setting the target temperature to the value of the average room temperature in summer plus 2 °C.
- ▷ Tap the **Apply** button.
 - ✓ The settings are saved and the product starts temperature control.
 - ⓘ The heating element has two status LEDs that indicate the current operating status and possible error states of the product.
- ▷ Pay attention to the respective display of the status LEDs during operation.

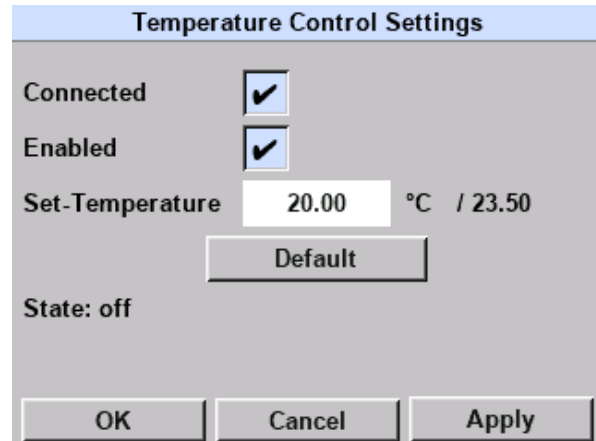

Figure 25: Configuring temperature control (example)

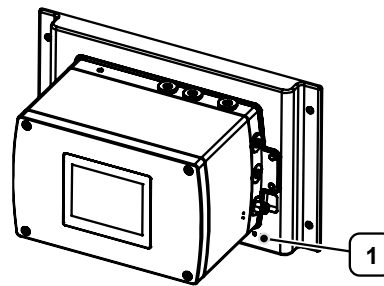

Figure 26: Status LEDs (example)

1 Status LED (2x)

Status display	Description
Red + yellow light up	Heating process (temperature < set temperature)
Blue + yellow light up	Cooling process (temperature > set temperature)
Green lights up	Set temperature reached (temperature = set temperature)
Violet lights up	Error: Communication error (Communication Error) <ul style="list-style-type: none"> ▷ Check that the product is correctly installed and that all cable connections are properly connected. ▷ Disconnect the power supply to the heating element for a few seconds. ▷ If the error persists, contact customer service.
Purple lights up + Yellow flashes (1 minute)	Error: Incorrect mode activated (Incorrect Mode Activation Error) <ul style="list-style-type: none"> ▷ Check that the product is correctly installed and that there is proper contact with the heating element. ▷ Disconnect the power supply to the heating element for a few seconds. ▷ If the error persists, contact customer service.

Table 5: LED status displays

Configuring temperature control (mobile device version)

In the mobile device version, the heater is integrated internally. This is activated **automatically** as soon as the ambient temperature falls below 19 °C (factory setting).

- ▷ Only adjust the target temperature if necessary.
- ▷ Tap the **Temperature control** button.
- ▷ Enter the desired target temperature.
 - ⓘ The factory setting of 19 °C is the recommended value and should generally be retained.
- ▷ Tap the **Apply** button.
 - ✓ The settings are saved and the product starts temperature control.



8.2 Carry out residual oil measurement

Relative and absolute concentration

Oil vapor usually consists of complex mixtures of molecules, not a single gas. The conversion to mg/m^3 is therefore based on the assumption of a typical average molar mass in accordance with ISO 8573-5, related to the vapor phase under near-normal conditions.

The performance data stated in the calibration certificate are based on single gas measurements with certified test gas.

- ppm values: typical deviation $\pm 10\%$
- mg/m^3 values: systematic deviation $\pm 20\%$ due to unknown molecular masses in the field



NOTE

Unknown molecular composition leads to increased uncertainty when determining the absolute value (mg/m^3).

Expected typical flow rates (accuracy approx. $\pm 10\%$)

The gas flow rate through the product depends on the applied process pressure; at lower flow rates, the response time is reduced.

- ▷ To ensure stable operation, maintain a gas flow rate between 200 ml/min and 550 ml/min.
- ▷ Carry out a zero point adjustment when switching to a different mean operating pressure ($\Delta p > 2$ bar).
 - ⓘ Further information can be found in chapter "8.1.1 Carry out zero point adjustment".

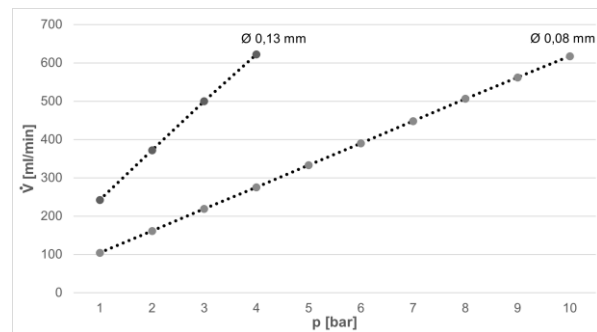

Figure 27: Flow rates with different standard orifices



CAUTION

Pressure surges or strong pressure fluctuations

The measurement technology used in the product basically works independently of the flow rate. However, rapid or large pressure changes (> 2 bar) can have effects that influence the measured value - especially in the sensitive measuring range of ISO air class I.

- ▷ Avoid pressure surges and major pressure fluctuations on the product to ensure reliable operation.

Query measurement data

The product displays current measurement data in several areas of the user interface depending on the context. These include the start screen, specific detailed views and function dialogs. In this way, all relevant information is available at all times during operation.



Open compact view via start screen

The following views are available on the home screen to display the measured values:

- **Main view:**
Absolute concentration in [mg/m³] (standard view)
- **Relative concentration:**
Relative concentration in [ppm]. No air classes are displayed in this view.
- **Trend view:**
Minimum and maximum values since the last reset.

- ▷ Tap the **Home** button.
✓ The home screen opens.
- ▷ Tap the **-->** button to switch to the next view.
- ▷ Tap the **Reset** button to restart the determination of the measured values.

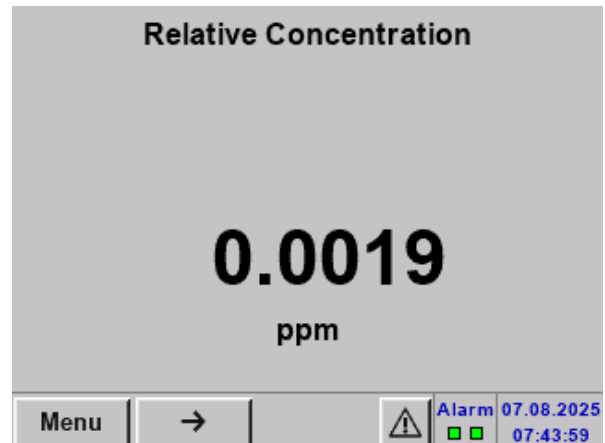

Figure 28: Relative concentration (example)

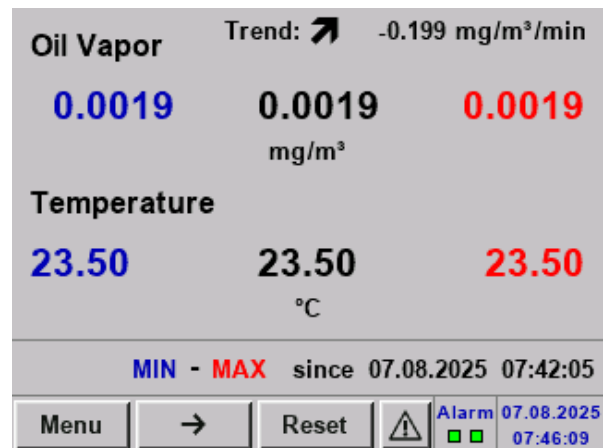

Figure 29: Trend view (example)



9 Maintenance and servicing



CAUTION

Safety instructions

- ▷ The product may only be serviced by a qualified electrician.
- ▷ Work on the electrical equipment of the product may only be carried out by qualified electricians or by instructed persons under the direction and supervision of a qualified electrician in accordance with the electrotechnical regulations.
- ▷ Spare parts must comply with the technical requirements specified by the manufacturer (CS INSTRUMENTS). This is always guaranteed with original spare parts.



NOTE

Unless expressly described otherwise, only begin maintenance and servicing work after

- the product has been disconnected from the power supply,
- the product has been switched off and secured against being switched on again.

9.1 Maintenance intervals

These maintenance intervals are the manufacturer's recommendations. The operator must check the intervals depending on the operating conditions and shorten them if necessary.

Interval	Interval Description
Monthly (every 730 operating hours)	see chapter 9.2 Clean product
	see chapter 9.3 Check operating parameters
	see chapter 9.4 Check cables
	see chapter 9.5 Check sensor sensitivity
Annually (every 8,760 operating hours)	see chapter 9.6 Check safety functions
	see chapter 9.7 Check mechanical components and connections
	see chapter 9.8 Check function and wear
	see chapter 9.9 Perform calibration
As required	see chapter 9.10 Update software

9.2 Clean product

Cleaning the housing

If the housing is dirty, clean it with solvent-free cleaning agents.

- ▷ Use a slightly damp, lint-free cloth to clean the housing regularly.
- ▷ Check the product for damage and corrosion.

Cleaning the touchscreen

If the touchscreen is dirty, clean it with solvent-free cleaning agents.

- ▷ Tap the Cleaning button.
 - ✓ The touchscreen is temporarily deactivated.
- ▷ Use a slightly damp, lint-free cloth to clean the touchscreen regularly.

9.3 Check operating parameters

Open detailed view

In addition to the compact display on the start screen, measurement data can also be called up in detail via the System Information menu item.

- ▷ Tap the **Menu** button.
 - ✓ The **main menu** opens.
- ▷ Tap the **System Information** button.
- ▷ Tap the **-->** button to switch to the next view.
- ▷ Tap the **Reset** button to restart the determination of the measured values.

Min/Max Values (1/4)	
Oil Vapor	0.0014 mg/m ³
Oil Vapor min	0.0014 mg/m ³
Oil Vapor max	0.0014 mg/m ³
Oil Vapor Resolution	0.0006 mg/m ³
Gas Temperature	23.50 °C
Gas Temperature min	23.50 °C
Gas Temperature max	23.50 °C

Back ← → Reset

Figure 30: Querying measurement results (example)

Check operating parameters

The current operating parameters must be checked for deviations.

- ▷ Record the current operating parameters of the product.
- ▷ Compare these with the values in chapter " 11.1 Technical data".
- ▷ Contact customer service if necessary.

9.4 Check cables



DANGER

Danger to life due to electrical voltage

During installation, maintenance or in the event of a fault, touchable conductive parts can carry dangerous voltages. Contact with uninsulated parts or mains voltage can lead to serious injury or death.

- ▷ Do not operate the product if power supply cables are damaged or housing parts are defective or removed.
- ▷ Strictly observe all locally applicable regulations and safety regulations.
- ▷ Only carry out work on electrical connections when the power supply is switched off. Secure the product against unintentional restarting.
- ▷ Check all electrical connections before commissioning and regularly during operation.



CAUTION

Danger from commissioning a damaged product

If a damaged product is installed or put into operation, it may result in functional failures, electrical hazards, or mechanical risks.

- ▷ Before each start-up, inspect the product, accessories, and all supply lines for visible damage, loose parts, or missing components.
- ▷ Immediately take any defective product out of operation immediately.

Check cables

Prerequisite

- The product is de-energized and freely accessible.

The electrical cables of the product must be checked regularly by a qualified person.

- ▷ Check the electrical cables for damage.



Check the plug-in power supply unit

Prerequisite

- The product is de-energized and freely accessible.
- ▷ Check the electrical plug-in power supply unit for visible damage to the housing, plug and cable.

9.5 Check sensor sensitivity

Open detailed view

In addition to the compact display on the start screen, measurement data can also be called up in detail via the System Information menu item.

- ▷ Tap the Menu button.
 - ✓ The main menu opens.
- ▷ Tap the System Information button.
- ▷ Tap the --> button to switch to the next view.
- ▷ Tap the Reset button to restart the determination of the measured values.

Min/Max Values (1/4)	
Oil Vapor	0.0014 mg/m ³
Oil Vapor min	0.0014 mg/m ³
Oil Vapor max	0.0014 mg/m ³
Oil Vapor Resolution	0.0006 mg/m ³
Gas Temperature	23.50 °C
Gas Temperature min	23.50 °C
Gas Temperature max	23.50 °C

Back
←
→
Reset

Figure 31: Querying measurement results (example)

Checking the sensor sensitivity

The sensitivity of the sensor must be checked regularly.

The oil vapor resolution diagnostic value indicates the currently achieved resolution of the oil vapor measurement in milligrams per cubic meter (mg/m³). It is calculated during operation using the statistical noise component in the measurement signal and the stored calibration curve.



NOTICE
Warning threshold
 If the value exceeds **0.0025 mg/m³**, reliable detection of the transition from air class I to air class II in accordance with ISO 8573 is no longer guaranteed.
 ▷ In this case, the system issues an error message.

- ▷ Check the oil vapor resolution diagnostic value in accordance with the applicable specifications.
 - ⓘ Possible causes of deteriorated resolution: Reduced lamp intensity, EMC interference or other electrical or physical influences in the system
- ▷ Carry out a calibration of the sensor unit if the sensitivity is no longer within the specified tolerances.
 - ⓘ Further information can be found in chapter "9.9 Perform calibration".

9.6 Check safety functions



WARNING
Housing cover not closed correctly after completion of installation or maintenance work
 The operating permit expires in accordance with the applicable regulations; possible danger from unprotected electrical or mechanical components.
 ▷ After completing installation or maintenance work, fold the housing cover completely back into its original position and secure it properly.



Check safety functions

The safety-relevant components must be checked for proper function and integrity.

Prerequisite

- The product is de-energized and freely accessible.
- ▷ Check existing safety devices (e.g. covers) for function and visible damage in order to minimize the risk of personal injury or damage to property.
- ▷ Contact customer service if necessary.

9.7 Check mechanical components and connections

Check mechanical components and connections

The mechanical and electrical connections of the system must be checked for tightness, integrity and leak tightness.

Prerequisite

- The product is de-energized and freely accessible.
- ▷ Check all pipe connections, hoses and screw connections for tightness and visible leaks.
- ▷ Carefully tighten any loose connections.
- ▷ Check for wear, cracks or leaks.
- ▷ Check the clamping points of the electrical installation for firm contact and freedom from corrosion.
- ▷ Carry out a leak test of the entire system.

9.8 Check function and wear

Check function and wear

The components that influence the control system and system operation must be checked for function and wear.

- ▷ Check the function and wear of the solenoid valves.
- ▷ Listen for audible switching noises, delayed reaction or leaks.
- ▷ Check the condition of the vacuum pump.
- ▷ Listen for unusual running noises, vibrations or loss of power.
- ▷ Simulate typical system states (e.g. error, warning, standby).
- ▷ Contact customer service if necessary.

9.9 Perform calibration

Observe calibration intervals

The user is always responsible for determining suitable calibration intervals.



NOTICE

Manufacturer's recommendation

To avoid possible errors at an early stage, a calibration should be carried out every 12 months.

- ▷ Carry out an initial recalibration of the product no later than 12 months after delivery - regardless of the operating conditions.

Increased maintenance is to be expected under the following conditions in particular:

- Extreme temperatures (especially low temperatures)
- Highly increased oil vapor concentrations / humid compressed air
- Falling or overloading of the product
- Interventions for repair purposes

▷ Observe the specifications in the quality management manual (QM system).

- ⓘ The calibration interval must be defined dynamically - preferably using a procedure anchored in the QM system. Without corresponding specifications, the determination is risk-based and based on economic considerations.



Frequent recalibration: higher operating costs
 Rare recalibration: risk of invalid measurement results

- ▷ Always have the product calibrated after special operating conditions.
 - ⓘ For applications with very high accuracy requirements (e.g. ISO air class I, oil vapor content < 0.01 mg/m³):
Recommended start interval: 6 months
With stable measurement recording: Interval extension to 12 months possible

Have a factory calibration carried out

- ▷ Send the sensor unit to the manufacturer (CS INSTRUMENTS).
 - ⓘ Further information can be found in chapter "9.13 Replace sensor unit".



NOTICE
Shipping the complete product

When shipping the complete product, insert the blanking plugs supplied into the pneumatic connections to protect the connections from dirt, moisture and damage during transportation.

- ▷ Insert the blanking plugs supplied into the pneumatic connections.

Calibration point	PPB-Vol	mg/m ³	ISO air class
1	Zero air (0)	<0,003	I
2	1	0,0032	I
3	2	0,0064	I
4	4	0,0128	II
5	8	0,0256	II
6	16	0,0513	II
7	32	0,1025	III
8	64	0,2051	III
9	128	0,4102	III
10	256	0,8204	III
11	512	1,6408	IV
12	1000	3,2047	IV

Table 6: Factory-set calibration points for compliance with ISO air quality classes in accordance with ISO 8573-1

9.10 Update software

9.10.1 Download software package

- ▷ Visit the manufacturer's homepage at (CS INSTRUMENTS).
- ▷ Download the appropriate software package.
 - ⓘ The current hardware and software versions along with the serial number are displayed under the About tab.
- ▷ Save the software package in the desired target directory or on the desired USB storage device.

9.10.2 Establish connection

- ▷ Connect the service/diagnostic interface (RS485) of the product to your computer.
 - ⓘ Further information can be found in chapter "5.2 Connect product".



NOTICE
Avoiding inconsistent data

The product is locked during an active connection with the computer. This prevents changes to the product and protects against inconsistent or incomplete data transfers.

- ▷ Do not disconnect manually during data transfer.

9.10.3 Performing a software update

The software update is carried out via the service software.

- ▷ Contact customer service to carry out the software update.

9.11 Retrofitting the alarm system



DANGER

Injury or death from touching live parts

When carrying out installation and maintenance work, you may encounter parts that carry dangerous voltages during operation. Touching live parts can lead to death.

- ▷ Work on electrical systems or equipment may only be carried out by qualified electricians or by instructed persons under the direction and supervision of a qualified electrician in accordance with electrotechnical regulations.

Retrofitting the alarm device

To retrofit an alarm device (e.g. warning light or siren), two jumpers must be set on the main circuit board.

Prerequisite

- The product is de-energized and freely accessible.

Tools

- T20 offset screwdriver (housing cover)
- ▷ Loosen the four screws (size 20) on the housing cover.
- ▷ Swing the housing cover open to the left-hand side.
 - ⓘ The main circuit board is located on the inside of the housing cover.
- ▷ Insert the two jumpers into the corresponding positions on the main circuit board (see "→ Figure 32: Setting jumpers (example)").
 - ⓘ The potential-free relay contacts are designed for low voltages and are only available after both jumpers have been set.
- ▷ Connect the desired alarm device accordingly.
- ▷ After completing the work, fold the housing cover completely back into its original position and secure it properly.

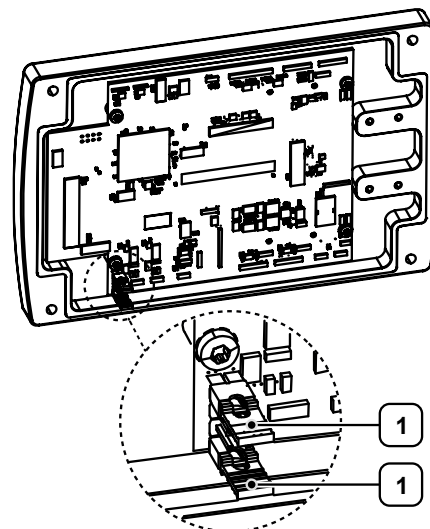

Figure 32: Setting jumpers (example)

1 Jumper

Designation	Plug type	Assignment	Plug
5 Alarm (alarm device, e.g. alarm pillar)	M12 (M)	Pin 1 ¹ (alarm 1 +) (light) Pin 2 ² (24 V DC) Pin 3 (GND - common earth connection) Pin 4 ³ (alarm 2 +) (siren) Pin 5 ⁴ (24 V DC)	

Table 7: Pin assignment

¹ together with pin 3 (GND)

² depending on application

³ together with pin 3 (GND)

⁴ depending on application

**WARNING****Housing cover not closed correctly after completion of installation or maintenance work**

The operating permit expires in accordance with the applicable regulations; possible danger from unprotected electrical or mechanical components.

- ▷ After completing installation or maintenance work, fold the housing cover completely back into its original position and secure it properly.

9.12 Retrofitting an external heating element

**DANGER****Injury or death from touching live parts**

When carrying out installation and maintenance work, you may encounter parts that carry dangerous voltages during operation. Touching live parts can lead to death.

- ▷ Work on electrical systems or equipment may only be carried out by qualified electricians or by instructed persons under the direction and supervision of a qualified electrician in accordance with electrotechnical regulations.

Installing and connecting the external heating element (stationary device variant)

Prerequisite

- Firmware version: **≥V1.25**
- Product is disassembled.

An external heating element can be retrofitted to the stationary device variant in order to stabilize the measuring environment and increase the accuracy and reliability of the measurement results.

- ▷ Position the heating element at the desired location and attach it to the four points provided.
- ▷ Remove the protective film from the heating element.
- ▷ Unscrew the supplied screws from the heating element.
- ▷ Place the product on the heating element.
- ▷ Place the washers on the screws and secure the product by screwing the screws in completely.
 - ⓘ The washers must **not** be placed between the heating element and the product, as this will impair the thermal coupling.
- ▷ Tighten the screws.
 - ⓘ Tightening torque: 0.8-1.0 Nm
- ▷ Plug the power supply cable of the heating element into the **PWR B [6]** connection on the product.
 - ⓘ Further information can be found in chapter "[5.2 Connect product](#)".
- ▷ Switch on the heating element on the software side.
 - ⓘ Further information can be found in chapter "[8.1.3 Ensure standard-compliant measurement using heating](#)".

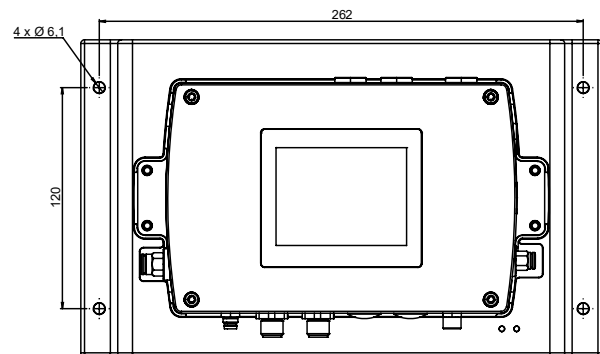

Figure 33: Drilling pattern with external heating element

9.13 Replace sensor unit



DANGER

Injury or death from touching live parts

When carrying out installation and maintenance work, you may encounter parts that carry dangerous voltages during operation. Touching live parts can lead to death.

- ▷ Work on electrical systems or equipment may only be carried out by qualified electricians or by instructed persons under the direction and supervision of a qualified electrician in accordance with electrotechnical regulations.

Replacing the sensor unit

The sensor unit stores the serial number, gas type, calibration data, lamp intensity and operating hours. It can be replaced on site; it is not necessary to send in the entire product.



WARNING

Danger due to electrostatic discharge (ESD)

Electrostatic discharge can permanently damage the sensor unit.

- ▷ Ground yourself before touching the sensor unit (e.g. via a grounded metal part).
- ▷ When shipping, only use the ESD-safe transport packaging supplied.



Prerequisite

- The product is de-energized and freely accessible.
- The system is depressurized.

Tools

- T20 offset screwdriver (housing cover)
- T10 offset screwdriver (sensor unit)

Materials

- Pre-calibrated sensor unit
- ▷ Remove the enclosed tool from the transport packaging.
- ▷ Loosen the four screws (size 20) on the housing cover.
- ▷ Open the housing cover to the left.
- ▷ Disconnect the two connection cables from the sensor unit.
- ▷ Loosen the four screws (size 10) on the stainless steel block.
- ▷ Remove the old sensor unit.
- ▷ Loosen the four screws (size 10) on the stainless steel block of the new unit.
- ▷ Remove the new sensor unit from the transport packaging.
- ⓘ Ensure that it is protected against mechanical damage and electrostatic discharge (ESD).
- ▷ Insert the new sensor unit.
- ⓘ Use the four new screws supplied (hexagon socket, size 10) and the new sealing ring.
- ▷ Tighten the screws hand-tight plus a quarter turn.
- ▷ Connect the connection cables to the appropriate connectors on the new sensor unit.
- ⓘ Both connectors are compatible with each other.
- ▷ Fold the housing cover back into its original position and secure it properly.
- ▷ Carefully fit the removed sensor unit into the transport packaging.
- ⓘ Ensure that it is protected against mechanical damage and electrostatic discharge (ESD).
- ▷ Send the sensor unit to the manufacturer (CS INSTRUMENTS).

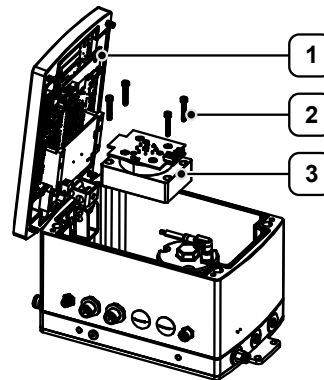

Figure 34: Replacing the sensor unit (example)

- | | | | |
|---|---------------|---|-------------|
| 1 | Housing cover | 3 | Sensor unit |
| 2 | Screw (4x) | | |

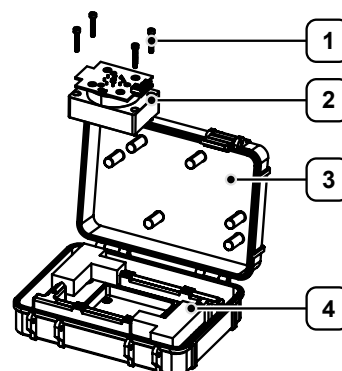

Figure 35: Packing the sensor unit (example)

- | | | | |
|---|-------------|---|--|
| 1 | Screw (4x) | 3 | Transport packaging |
| 2 | Sensor unit | 4 | Hexagon socket screwdriver (T10 / T20) |



WARNING

Housing cover not closed correctly after completion of installation or maintenance work

The operating permit expires in accordance with the applicable regulations; possible danger from unprotected electrical or mechanical components.

- ▷ After completing installation or maintenance work, fold the housing cover completely back into its original position and secure it properly.

9.14 Error states

9.14.1 Correct error states

Correcting error states

Warnings continue to allow measurement without affecting the measured value. Measurement is not possible in the event of errors.

- ▷ Contact customer service if necessary.
- ▷ Further information can be found in chapter "[11.4 Register assignment \(incl. error and warning messages\)](#)".

9.14.2 Restore factory settings

Restoring the factory settings

If necessary, the product can be reset to the factory settings to restore the delivery status.

- ▷ Tap the **User customizations** button.
- ▷ Tap the **Default** button.

The screenshot shows a dialog box titled "Customer Adjustment". It has a light blue header. Below the header, there are two rows of settings. The first row is "Offset" with a text input field containing "0" and a unit "µV" to its right. Below the input field, the range "-2500 .. 1500" is displayed. The second row is "Response Factor" with a text input field containing "1.00". Below this input field, the range "0.2 .. 5.0" is displayed. At the bottom of the dialog, there are three buttons: "Default", "OK", and "Cancel".

Figure 36: Reset offset (example)

Parameters	Factory setting
Offset [µV]	0,0
Response factor	1,0

9.15 Customer service

For rapid processing by customer service

Prerequisite

- Material number (product rating plate)
- Serial number (product rating plate)
- ▷ Describe the problem as precisely as possible.
- ▷ Make a note of any error messages displayed.
- ▷ Inform customer service about:
 - When does the problem occur?
 - How often does it occur?
 - What changes were last made to the product, the configuration, or the environment?



10 Decommissioning and disposal

Decommissioning

Decommissioning is defined as an extended period of non-use of the components. The components must then be protected from external influences.

- ▷ If necessary, disconnect the components from the power supply.
- ▷ Properly package the components if they will not be used for an extended period.
- ▷ Store the components in a manner that prevents exposure to significant temperature fluctuations. Resulting condensation can lead to moisture buildup and cause corrosion.

Disposal

Parts and components that have reached the end of their service life, e.g. due to wear, corrosion and mechanical stress, must be properly disposed of after disassembly, in accordance with national regulations.

The product and packaging contain recyclable materials that must not be disposed of with residual waste.

- ▷ Separate the components after recycling.
 - ⓘ Disposal code according to the European Waste Catalog (EWC) 16 02 14, electrical and electronic devices and their components.
- ▷ Dispose of the components in an environmentally responsible manner, in accordance with local regulations or through a certified disposal company.



NOTE

Information on environmentally responsible disposal can be obtained from local authorities, or certified disposal companies.

- ▷ Alternatively, you can return the product to the manufacturer (CS INSTRUMENTS) at the end of its service life.

11 Appendix

11.1 Technical data

Parameters	Specification	Unit
Weight	Stationary device variant: 6.8	kg
	Mobile device variant: 6.6	
Power supply	24	V DC
Power consumption	Without option: max. 5.4	W
	With alarm device: max. 18	
	With heating element: max. 45	
Measuring range	0.001-1 (\pm ~0.003 - ~4 mg/m ³ residual oil content (typical))	ppm
Measurement technology	Photo-ionization detector (PID)	
Detection limit	~0,001	mg/m ³
Measuring medium	Compressed air, nitrogen (other gases available on request)	
Measured variables	mg oil/Nm ³ , ppm (based on 1.0 bar [abs], +20 °C, 0 % r. h., in accordance with ISO 8573-1)	
Sample gas flow rate	~0,5	l/min
Media temperature	+20...+45 (short-term: +70)	°C
Media humidity	max. 40% relative humidity, non-condensing, pressure dew point max. +10 °C	
Detectable substances	(functional) hydrocarbons, aromatics	
Operating pressure	3-9	bar overpressure
Digital output	RS485 (Modbus-RTU)	
Analog output	1 x 4...20 mA (galvanically isolated) (optional: 2 x 4...20 mA)	
Alarm output	2 x for external signal processing	
Materials in contact with media	Stainless steel 1.4404, FKM, PPS (40% glass fiber reinforced)	
Area of application	Indoor use	
Degree of soiling	2	
Operating temperature	+5...+50 (recommendation: +20...+45)	°C
Storage temperature	-10... 60	°C
Air humidity	max. 80% relative humidity, non-condensing	
Altitude clearance	up to 4000 m above sea level (use above 2000 m only with appropriately approved power supply unit)	
Protection class	IP54	

11.2 Dimensions

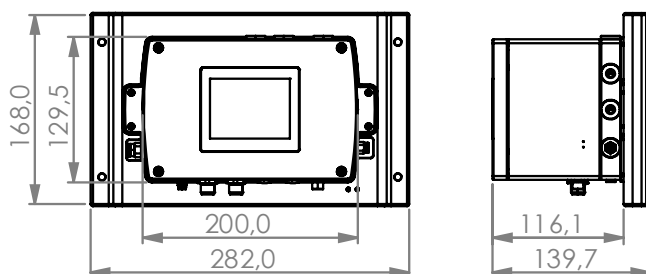

Figure 37: Dimensions OIL CHECK 500 | stationary device variant

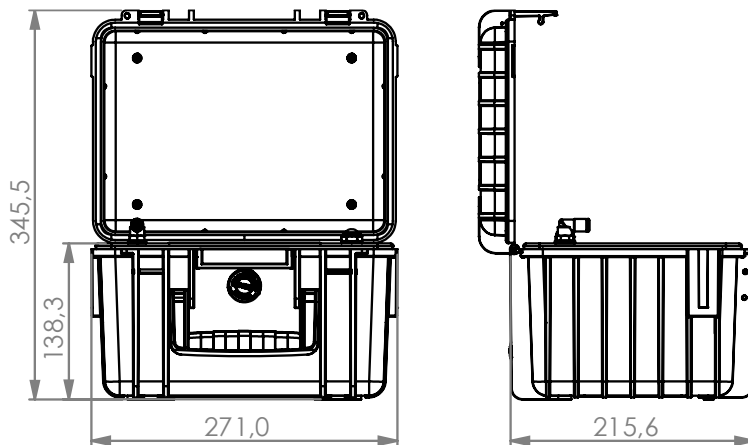

Figure 38: Dimensions OIL CHECK 500 | mobile device version

11.3 Spare parts list

Material no.	Designation	Quantity
0699 8080	Sensor unit	1
0554 0115	Power supply unit [18 W]	1
0554 1115	Power supply unit [40 W]	1

11.4 Register assignment (incl. error and warning messages)

Register	Designation Value	Data type	Data type Unit
1000	Oil vapor stationary	float	mg/m ³
1002	Oil vapor mobile	float	mg/m ³
1004	Oil vapor stationary	float	ppm
1006	Oil vapour mobile	float	ppm
1008	Gas temperature	float	°C
1010	Gas pressure	float	mBar
1012	Internal relative humidity	float	%
1014	Lamp intensity	float	%
1016	Pressure ambient	float	mBar
1018	Pressure process	float	mBar
1020	Device error	uint32	Bitmask 1
1022	Device warning	uint32	Bitmask 2

Table 8: Register assignment (RS485 connections)

Bit pos.	Error	Range	Note
0	Power supply (24 V) too low	< 20 V	Check supply!
1	Power supply (24 V) too high	> 28 V	Avoid overvoltage!
2	Sensor voltage (3.4 V) too low	< 3,1 V	Check sensor power supply
3	Sensor voltage (3.4 V) too high	> 3,7 V	Possible electronics error
4	Gas temperature too low	< 5 °C	Stop measurement, heat device (only relevant for start if applicable)
5	FA sensor error	Error code (0x...)	Check sensor
6	PID control error	-	Internal control error / contact customer service
7	Humidity too high when appliance is cold	> 80% / < 10 °C	Preheat the appliance
8	Lamp intensity too low	< 70%	Maintenance recommended / contact customer service



Bit pos.	Error	Range	Note
9	Process pressure too low	< 200 mbar	Check gas supply
10	Error in the actuator system	Error code (0x...)	Check actuator / contact customer service

Table 9: Implemented error messages (register 1020)

Bit pos.	Warning	Range	Note
0	Power supply	< 22 V / > 27 V	Contact customer service
1	Sensor voltage	< 3.2 V / > 3.6 V	Contact customer service
2	Gas temperature	< 10 °C / > 60 °C	Avoid risk of condensation / check during continuous operation
3	Internal relative humidity	-	Increase temperature or reduce humidity
4	Light source intensity	< 80%	Contact customer service / schedule maintenance
5	Oil vapor resolution	-	Contact customer service / check measurement quality
6	Pneumatic system	-	Perform diagnosis; if warning persists, contact customer service
7	Actuator system	-	Perform diagnostics; contact customer service if warning persists

Table 10: Implemented warning messages (register 1022)



11.5 Declaration of conformity



KONFORMITÄTSERKLÄRUNG DECLARATION OF CONFORMITY

Wir CS Instruments GmbH & Co.KG
We Zindelsteiner Straße 15, 78052 Villingen-Schwenningen

Erklären in alleiniger Verantwortung, dass das Produkt
Declare under our sole responsibility that the product

Öldampfmessung: OIL CHECK 500
Oil vapour measurement: OIL CHECK 500

den Anforderungen folgender Richtlinien entsprechen:
We hereby declare that above mentioned components comply with requirements of the following EU directives:

Elektromagnetische Verträglichkeit Electromagnetic compatibility	2014/30/EU 2014/30/EC
RoHS (Restriction of certain Hazardous Substances)	2011/65/EC & 2015/863/EC

Angewandte harmonisierte Normen:

Harmonised standards applied:

EMV-Anforderungen EMC requirements	EN 55011:2016 + A2:2021-04 EN 61326-1: 2013-07 EN 61000-3-2:2014 EN 61000-3-3:2013
RoHS (Restriction of certain Hazardous Substances)	EN IEC 63000:2018

Das Produkt ist mit dem abgebildeten Zeichen gekennzeichnet.
The product is labelled with the indicated mark.



Harrislee, den 17.04.2024

Wolfgang Blessing Geschäftsführer



CS INSTRUMENTS GmbH & Co. KG

Zindelsteiner Str. 15 | 78052 VS-Tannheim | GERMANY

Tel. +49 7705 978 99 0 | info@cs-instruments.com

www.cs-instruments.com