



VA 520 - Inline flow meter

Modbus-RTU output

4...20 mA output for present flow

Pulse output for total flow (counter reading), galvanically isolated or M-Bus (optionally)

NEW: Integrated pressure sensor (optional)

Measuring unit can be unscrewed: Removal of the entire measuring section not necessary, no by-pass necessary

Display head rotatable by 180° e.g. in case of reverse flow direction

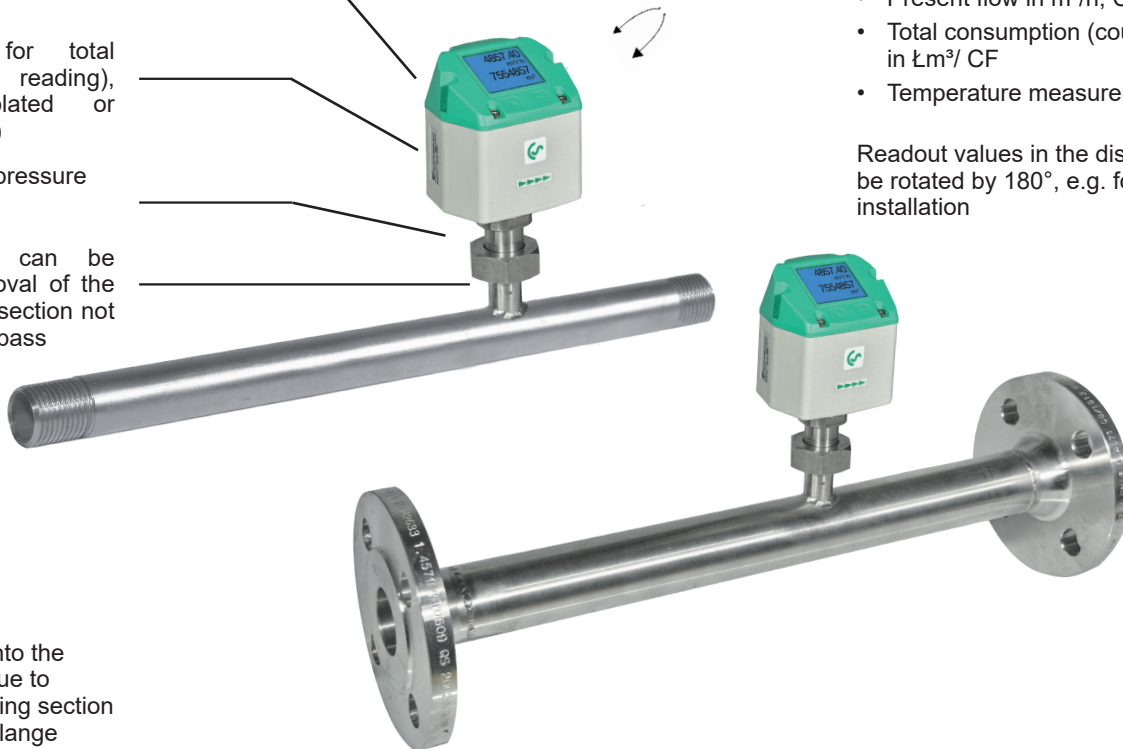

Display shows 2 values at the same time:

- Present flow in m³/h, CFM,...
- Total consumption (counter reading) in Lm³/ CF
- Temperature measurement

Readout values in the display can be rotated by 180°, e.g. for overhead installation

Easy installation into the existing pipeline due to integrated measuring section and welded neck flange (according to EN 1092-1 PN 40)

High measuring accuracy via the integrated measuring section defined measuring section (inlet and outlet section)



The sensor can be removed and cleaned



With a key stroke:

- Reset counter reading
- Select units
- Zero-Point adjustment, leak flow volume suppression



Option:

Bi-directional measurement. Blue or green arrows in the display indicate the direction of flow.

A meter reading is available for each flow direction.



Application-technological features of the flow meters VA 520:

- Digital interfaces such as Modbus-RTU, Ethernet (PoE) and M-Bus enable connection to higher-level systems such as energy management systems, building management systems, PLC,...
- Easy and cost-effective installation
- Units freely selectable via keys on the display CF, lbs, CFM
- Compressed air counter up to 1,999,999,999 m³ can be reset to "zero" via keypad
- Analog output 4...20 mA, pulse output (electrically isolated)
- High measuring accuracy even in the lower measuring range (ideal for leakage measurement)
- Negligible pressure loss
- Calorimetric measuring principle, no additional pressure and temperature measurement necessary, no mechanically moved parts
- Comprehensive diagnostic functions can be read out on the display or remote access via Modbus-RTU such as exceeding max./min values °F, calibration cycle, error codes, serial number. All parameters can be read out and changed via Modbus

For further accessories refer to pages 126 to 130



Measuring range - Flow VA 520

		1/4"	3/8"	1/2"	3/4"	1"	1 1/4"	1 1/2"	2"	2 1/2"	3"
		l/min (cfm)	m³/h (cfm)	m³/h (cfm)	m³/h (cfm)	m³/h (cfm)	m³/h (cfm)	m³/h (cfm)	m³/h (cfm)	m³/h (cfm)	m³/h (cfm)
Reference conditions DIN 1945 / ISO 1217: 68 °F, 14 psi											
Air	Low-Speed (164 ft/s)	25 (0.9)	225 NI/min (8)	20 (14)	45 (25)	75 (45)	140 (80)	195 (115)	320 (190)	550 (325)	765 (450)
	Standard (304 ft/s)	50 (1.8)	25 (14.7)	45 (25)	85 (50)	145 (85)	265 (155)	365 (215)	600 (350)	1025 (600)	1420 (835)
	Max (607 ft/s)	105 (3.6)	50 (29.4)	90 (50)	175 (100)	290 (170)	530 (310)	730 (430)	1195 (700)	2050 (1205)	2840 (1670)
	High-Speed (735 ft/s)	130 (4.5)	60 (35.3)	110(60)	215 (125)	355 (210)	640 (375)	885 (520)	1450 (850)	2480 (1460)	3440 (2025)
Setting to DIN 1343: 32 °F, 14.7 psi											
Argon (Ar)	Low-Speed (164 ft/s)	45 (1.5)	330 NI/min (11.7)	35 (20)	75 (40)	120 (70)	220 (130)	305 (180)	505 (295)	865 (510)	1200 (705)
	Standard (304 ft/s)	85 (3)	35 (20.5)	70 (40)	135 (80)	230 (135)	415 (245)	570 (335)	935 (550)	1605 (945)	2225 (1310)
	Max (607 ft/s)	170 (6)	75 (44.1)	140 (80)	275 (160)	460 (270)	830 (485)	1140 (670)	1870 (1100)	3205 (1885)	4440 (2615)
	High-Speed (735 ft/s)	205 (7.2)	95 (55.9)	170 (100)	335 (195)	555 (325)	1005 (590)	1385 (815)	2265 (1330)	3880 (2285)	5380 (3165)
Carbondi-oxide (CO2)	Low-Speed (164 ft/s)	25 (0.9)	225 NI/min (7.9)	20 (14)	45 (25)	75 (45)	140 (80)	195 (115)	320 (185)	545 (320)	760 (445)
	Standard (304 ft/s)	50 (1.8)	25 (14.7)	45 (25)	85 (50)	145 (85)	260 (155)	360 (210)	590 (345)	1015 (595)	1405 (825)
	Max (607 ft/s)	105 (3.6)	50 (29.4)	90 (50)	175 (100)	290 (170)	525 (305)	720 (425)	1185 (695)	2030 (1190)	2810 (1655)
	High-Speed (735 ft/s)	130 (4.5)	60 (35.3)	105 (60)	210 (125)	350 (205)	635 (370)	875 (515)	1430 (840)	2455 (1445)	3405 (2000)
Nitrogen (N2)	Low-Speed (164 ft/s)	25 (0.9)	205 NI/min (7.2)	20 (13)	40 (25)	70 (40)	130 (75)	180 (105)	295 (175)	505 (300)	705 (415)
	Standard (304 ft/s)	50 (1.5)	20 (11.7)	40 (20)	80 (45)	135 (75)	240 (140)	335 (195)	550 (320)	945 (555)	1305 (770)
	Max (607 ft/s)	100 (3.3)	45 (26.4)	80 (45)	160 (95)	270 (155)	485 (285)	670 (395)	1100 (645)	1885 (1110)	2610 (1535)
	High-Speed (735 ft/s)	120 (4.2)	55 (32.3)	100 (55)	195 (115)	325 (190)	590 (345)	815 (475)	1330 (780)	2280 (1340)	3165 (1860)
Oxygen (O2)	Low-Speed (164 ft/s)	25 (0.9)	215 NI/min (7.5)	20 (13)	45 (25)	75 (40)	135 (80)	185 (110)	305 (180)	525 (310)	730 (430)
	Standard (304 ft/s)	50 (1.8)	20 (11.7)	40 (25)	80 (45)	140 (80)	250 (145)	345 (205)	570 (335)	980 (575)	1355 (795)
	Max (607 ft/s)	100 (3.6)	45 (26.4)	85 (50)	165 (95)	280 (165)	505 (295)	695 (410)	1140 (670)	1955 (1150)	2710 (1590)
	High-Speed (735 ft/s)	125 (4.2)	55 (32.3)	105 (60)	205 (120)	340 (200)	610 (360)	845 (495)	1380 (810)	2365 (1390)	3280 (1930)
Nitrous oxide (N2O)	Low-Speed (164 ft/s)	25 (0.9)	220 NI/min (7.7)	20 (14)	45 (25)	75 (45)	140 (80)	190 (110)	315 (185)	540 (320)	750 (440)
	Standard (304 ft/s)	50 (1.8)	20 (11.7)	40 (25)	85 (50)	140 (85)	260 (150)	355 (210)	585 (345)	1005 (590)	1395 (820)
	Max (607 ft/s)	105 (3.6)	45 (26.4)	85 (50)	170 (100)	285 (170)	520 (305)	715 (420)	1170 (690)	2010 (1180)	2785 (1640)
	High-Speed (735 ft/s)	125 (4.5)	60 (35.3)	105 (60)	210 (120)	345 (205)	630 (370)	865 (510)	1420 (835)	2435 (1430)	3375 (1985)
Natural gas (NG)	Low-Speed (164 ft/s)	15 (0.6)	130 NI/min (4.5)	14,4 (8)	25 (15)	45 (25)	85 (50)	115 (65)	190 (110)	325 (190)	450 (265)
	Standard (304 ft/s)	30 (0.9)	14 (8.8)	25 (15)	50 (30)	85 (50)	155 (90)	215 (125)	355 (205)	605 (355)	840 (495)
	Max (607 ft/s)	60 (2.1)	25 (14.7)	50 (30)	105 (60)	170 (100)	310 (185)	430 (250)	705 (415)	1210 (710)	1680 (985)
	High-Speed (735 ft/s)	75 (2.7)	35 (20.5)	65 (35)	125 (70)	210 (120)	380 (220)	520 (305)	855 (500)	1465 (865)	2035 (1195)



Optional: Connection to different Bus systems

There are different options available for connection to modern Bus systems:

- Ethernet interface Modbus TCP/Modbus PoE
- M-BUS
- Modbus-RTU
- Profibus DP interface
- Profinet interface
- HART
- IO-Link



Ethernet Modbus TCP
M12 Ethernet port, x-coded

For further accessories refer to pages 126 to 130





VA 520 - Inline flow meter

Example order code VA 520:

0695 xxxx_B1_C1_E1_F1_G1_H1_K1_L1_M1_N1_O1_R1_Y1

Measuring range (see table)	
B1	Max version (607 ft/s)
B2	Low-speed version (164 ft/s)
B3	Standard version (304 ft/s)
B4	High-speed version (735 ft/s)

Process connection	
C1	R male thread
C2	NPT male thread (only in 1.4404)
C3	Flange DIN EN 1092-1
C4	Flange ANSI 16.5 Class 150 lbs
C5	Flange ANSI 16.5 Class 300 lbs

Option signal outputs / bus connection	
E1	1 x 4...20 mA analog output (not electrically isolated), pulse output, RS 485 (Modbus-RTU)
E2	M-Bus, 1 x 4...20 mA analog output (not electrically isolated), RS 485 (Modbus-RTU)
E4	Ethernet interface (Modbus / TCP), 1 x 4...20 mA analog output (not electrically isolated), RS 485 (Modbus-RTU)
E5	Ethernet interface PoE (Power over Ethernet) (Modbus/TCP), 1 x 4...20 mA analog output (not electrically isolated), RS 485 (Modbus-RTU)
E6	IO-Link, 1 x 4...20 mA analog output (not galvanically isolated), RS 485 (Modbus RTU), pulse output not applicable

Adjustment/calibration	
F1	No real gas adjustment - gas type configuration per gas constant
F2	Real gas adjustment in the gas type selected below

Gas type	
G1	Compressed air
G2	Nitrogen (N2)
G3	Argon (Ar)
G4	Carbon dioxide (CO2)
G5	Oxygen (O2)
G6	Nitrous oxide (N2O)
G7	Natural gas (NG)
G8	Helium (He) (real gas adjustment F2 required)
G9	Propane (C3H8) (real gas adjustment F2 required)
G10	Methane (CH4)
G12	Further gas / please indicate gas type (on request)
G13	Gas mixture / please indicate mixture ratio (on request)

Reference standard	
H1	20 °C, 1000 mbar
H2	0 °C, 1013,25 mbar
H3	15 °C, 981 mbar
H4	15 °C, 1013,25 mbar

Maximum pressure	
K1	16 bar (232 psi)
K2	40 bar (580 psi)

Surface condition	
L1	standard version
L2	Special cleaning - oil and grease free (e. g. for oxygen applications and so on)
L3	Silicone-free version including special cleaning oil- and grease-free

Accuracy class	
M1	± 1.5% of the measured value ± 0.3% f.s. (standard)
M2	± 1% of the measured value ± 0.3% f.s. (precision)

Approvals	
N1	Non-explosive area - no approval
N3	DVGW approval for natural gas (max. pressure 232 psi)

Bi-directional measurement	
O1	without
O2	with (2x 4...20 mA analog output, pulse output) Above omitted with Ethernet and M-Bus

Special measuring range	
R1	Special measuring range (please specify when placing order)

Option pressure measurement (only with: G1, G2, G3, K1, L1, N1, O1)	
Y1	without pressure sensor
Y2	with integrated pressure sensor 0...232 psi(g) (Output only via digital interfaces)
Y3	with integrated pressure sensor 145...29.01psi (Output only via digital interfaces)



Order no. VA 520

DESCRIPTION (Flange version) / Stainless steel 1.4404	ORDER NO.
VA 520 flow meter with integrated DN 15 measuring section with flange	0695 2521
VA 520 flow meter with integrated DN 20 measuring section with flange	0695 2522
VA 520 flow meter with integrated DN 25 measuring section with flange	0695 2523
VA 520 flow meter with integrated DN 32 measuring section with flange	0695 2526
VA 520 flow meter with integrated DN 40 measuring section with flange	0695 2524
VA 520 flow meter with integrated DN 50 measuring section with flange	0695 2525
VA 520 flow meter with integrated DN 65 measuring section with flange	0695 2527
VA 520 flow meter with integrated DN 80 measuring section with flange	0695 2528

DESCRIPTION	ORDER NO.	ORDER NO.
	Stainless steel 1.4404 NPT	Stainless steel 1.4301 BSP
VA 520 flow meter with 1/4" measuring section	0695 1520	0695 0520
VA 520 flow meter with 3/8" measuring section	0695 1527	0695 0527
VA 520 flow meter with 1/2" measuring section	0695 1521	0695 0521
VA 520 flow meter with 3/4" measuring section	0695 1522	0695 0522
VA 520 flow meter with 1" measuring section	0695 1523	0695 0523
VA 520 flow meter with 1 1/4" measuring section	0695 1526	0695 0526
VA 520 flow meter with 1 1/2" measuring section	0695 1524	0695 0524
VA 520 flow meter with 2" measuring section	0695 1525	0695 0525

ACCESSORIES	ORDER NO.
ISO calibration certificate (5 calibration points) for VA sensors	3200 0001
Additional calibration curve stored in the sensor	Z695 5011
Certificate of origin	Z695 5012
Closing cap for measuring section in aluminium	0190 0001
Closing cap for measuring section stainless steel 1.4404	0190 0002
Connection cable for VA/FA series, 16 ft	0553 0104
Connection cable for VA/FA sensors, 32 ft	0553 0105
Ethernet connection cable length 16 ft M12 plug x-coded (8 pin) to RJ 45 plug	0553 2503
Ethernet connection cable length 32 ft M12 plug x-coded (8 pin) to RJ 45 plug	0553 2504

For further accessories refer to pages 106-120

TECHNICAL DATA VA 520

Parameters:	m ³ /h, CFM (1000 mbar, 20 °C) in case of compressed air or Nm ³ /h, NI/min (1013 mbar, 0 °C) in case of gases
Units adjustable via keys at display:	m ³ /h, m ³ /min, CFM, l/s, ft/min, cfm, m/s, kg/h, kg/min, g/s, lb/min, lb/h
Sensor:	Thermal mass flow sensor
Measured medium:	Air, gases
Gas types are adjustable over CS service software or CS data logger:	Air, nitrogen, argon, CO ₂ , oxygen
Measuring range:	See table above
Accuracy: (o. M. V. = of measured value) (o. F. S. = of full scale)	± 1.5% of m.v. ± 0.3% of f.s. on request: ± 1% of m.v. ± 0.3% of f.s.
Operating temperature:	-22...176 °F -25...349 °F with pressure sensor
Operating pressure:	-14.5 to 232 psi optionally up to PN 40
Digital output:	RS 485 interface, (Modbus-RTU), optional: Ethernet interface PoE), M-Bus, IO-Link
Analog output:	4...20 mA for CFM
Pulse output:	1 pulse per CF or per litre electrically isolated. Pulse weight can be set on the display. Alternatively, the pulse output can be used as an alarm relay
Supply:	18...36 VDC, 5 W
Burden:	< 500 Ω
Housing:	Polycarbonate (IP 65)
Measuring section:	Stainless steel, 1.4404 or 1.4301
Mounting position:	any

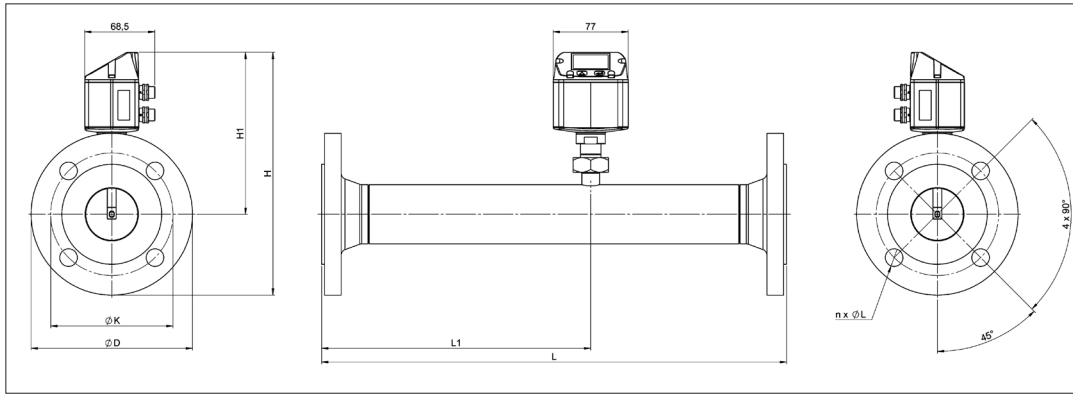

VA 520 - Flange

Flange DIN EN 1092-1

Measuring section	Outer pipe		Inner pipe		L	L1	H	H1	ØD	ØK	n x ØL
	mm	Inch	mm	Inch	Inch	Inch	Inch	Inch			
1/2"	21.3	0.84	16.1	0.63	11.8	8.27	8.3	6.5	95	65	4 x 14
3/4"	26.9	1.06	21.7	0.85	18.7*	10.83	8.5	6.5	105	75	4 x 14
1"	33.7	1.34	27.3	1.07	18.7*	10.83	8.7	6.5	115	85	4 x 14
1 1/4"	42.4	1.67	36.0	1.41	18.7*	10.83	9.2	6.5	140	100	4 x 18
1 1/2"	48.3	1.90	41.9	1.65	18.7*	10.83	9.4	6.5	150	110	4 x 18
2"	60.3	2.37	53.1	2.09	18.7*	10.83	9.7	6.5	165	125	4 x 18
2 1/2"	76.1	3.0	68.9	2.71	18.7*	10.83	10.5	6.9	185	145	8 x 18
3"	88.9	3.5	80.9	3.19	18.7*	10.83	10.8	6.9	200	160	8 x 18

*Attention: Shortened inlet section. Please observe the recommended minimum inlet section (length = 15 x inner diameter) on site.

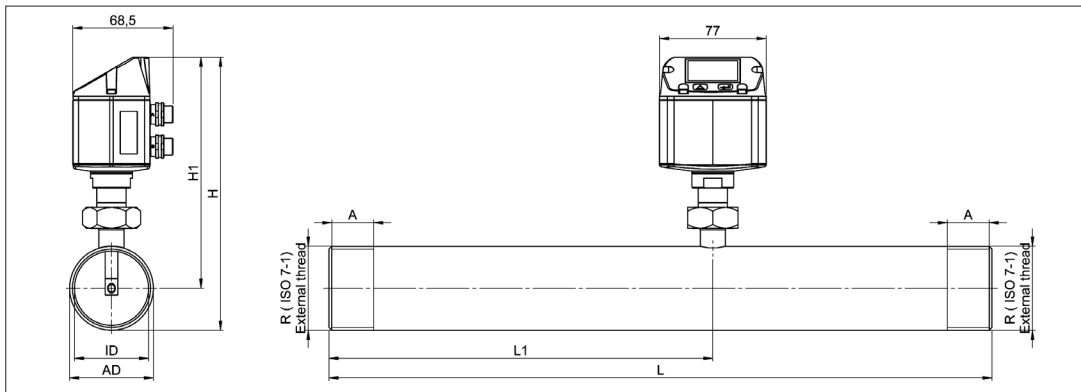

VA 520 - Thread

Connection thread	Outer pipe		Inner pipe		L	L	L1	L1	H	H	H1	H1	A	A
	mm	Inch	mm	Inch	Inch	mm	Inch	mm	Inch	mm	Inch	mm	Inch	mm
R 1/4"	13.7	0.54	8.9	0.35	7.6	194	5.3	137	6.8	174.7	6.5	165.7	0.5	15
R 3/8"	17.2	0.68	12.5	0.49	11.8	300	7.9	200	6.9	175	6.5	165.7	0.5	15
R 1/2"	21.3	0.84	16.1	0.63	11.8	300*	8.2	210	6.9	176.4	6.5	165.7	0.7	20
R 3/4"	26.9	1.06	21.7	0.85	18.7	475*	10.8	275	7.0	179.2	6.5	165.7	0.7	20
R 1"	33.7	1.34	27.3	1.07	18.7	475*	10.8	275	7.1	182.6	6.5	165.7	0.9	25
R 1 1/4"	42.4	1.67	36.0	1.41	18.7	475*	10.8	275	7.3	186.9	6.5	165.7	0.9	25
R 1 1/2"	48.3	1.90	41.9	1.65	18.7	475*	10.8	275	7.3	186.9	6.5	165.7	0.9	25
R 2"	60.3	2.37	53.1	2.09	18.7	475*	10.8	275	7.7	195.9	6.5	165.7	1.1	30

*Attention: Shortened inlet section. Please observe the recommended minimum inlet section (length = 15 x inner diameter) on site!