

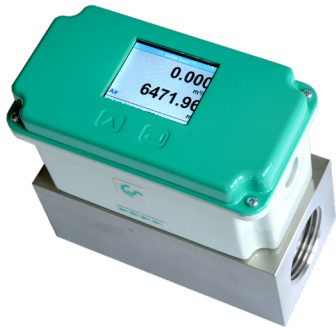

## VA 525 - Compact inline flow sensor for air and nitrogen

No inlet section necessary – integrated flow straightener – optional pressure sensor

The VA 525 combines modern digital interfaces for connection to an energy monitoring system with a small, compact design. The VA 525 is always used when many machines (compressed air consumers) are to be integrated into an energy monitoring network.



Readout values in the display can be rotated by 180°, e.g. for overhead installation

### Display shows 2 values at the same time:

- Present flow in m<sup>3</sup>/h, CFM, SCFM, CFH
- Total consumption (counter reading) in CF, l, lbs
- Temperature measurement
- **Optional:** Pressure measurement

### Advantages at a glance:

- Compact, small design - for use in machines, behind maintenance unit on the end consumer
- Optionally with conventional analog signals (4...20 mA and pulse) or digital interfaces such as Modbus-RTU, Ethernet (also PoE), M-Bus
- All interfaces are freely programmable via the display

### Screw-in thread:

Easy installation into the existing pipe via the integrated measuring section (suitable for 1/4", 1/2", 3/4", 1", 1 1/4", 1 1/2" or 2" lines)

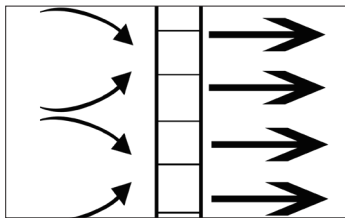

Integrated flow straightener - no inlet section necessary

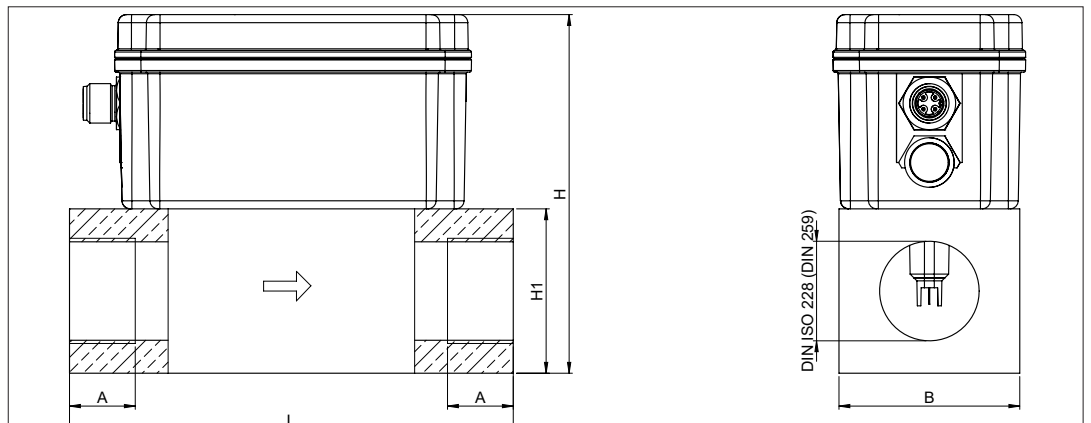

### With a key stroke:

- Reset counter reading
- Select units
- Implement Parameters

### Flow measuring ranges VA 525 (max version 185 m/s) for compressed air (ISO 1217:1000 mbar, 20 °C) Measuring ranges for other types of gas see pages 104 to 107

Measuring section	Thread	Measuring range full scales		L	B	H1	H	A
		m <sup>3</sup> /h	cfm					
DN 8	NPT 1/4"	105 l/min	3.6	135	55	50	109.1	15
DN 15	NPT 1/2"	90 m <sup>3</sup> /h	50	135	55	50	109.1	20
DN 20	NPT 3/4"	170 m <sup>3</sup> /h	100	135	55	50	109.1	20
DN 25	NPT 1"	290 m <sup>3</sup> /h	170	135	55	50	109.1	25
DN 32	NPT 1 1/4"	530 m <sup>3</sup> /h	310	135	80	80	139.1	25
DN 40	NPT 1 1/2"	730 m <sup>3</sup> /h	430	135	80	80	139.1	25
DN 50	NPT 2"	1195 m <sup>3</sup> /h	700	135	80	80	139.1	30



Example order code VA 525:

0695 5250\_A1\_B1\_C1\_D1\_E1\_F1\_G1\_H1\_I1\_J1\_K1\_L1\_M1\_N1\_R1

Measuring section	
A1	1/4"
A2	1/2"
A3	3/4"
A4	1"
A5	1 1/4"
A6	1 1/2"
A7	2"
Threaded version	
B1	G female thread
B2	NPT Female Thread (With adapter)
Material type	
C1	Aluminum
Adjustment/calibration	
D1	No real gas adjustment - gas type configuration per gas constant
D2	Real gas adjustment in the gas type selected below
Gas type	
E1	Compressed air
E2	Nitrogen (N2)
Measuring range (see table)	
F1	Low-speed version (164 ft/s)
F2	Standard version (304 ft/s)
F3	Max version (607 ft/s)
F4	High-speed version (735 ft/s)
Reference standard	
G1	20 °C, 1000 mbar
G2	0 °C, 1013,25 mbar
G3	15 °C, 981 mbar
G4	15 °C, 1013,25 mbar
Display option	
H1	with integrated display
H2	without display
Pressure measurement option	
I1	without pressure sensor
I2	With integrated pressure sensor 0...232 psi (output only via digital interfaces)
I3	with integrated pressure sensor 0.15...29 psi (abs), for vacuum applications (output only via digital interfaces)
Signal output / bus connection option	
J1	1x 4...20 mA analog output for present flow and pulse output
J2	Modbus-RTU (RS485)
J3	Ethernet interface (Modbus/TCP)
J4	Ethernet interface Power over Ethernet (Modbus/TCP)
J5	M-Bus
Flow Straightener	
K1	with integrated flow straightener, no additional inlet section necessary (with measuring section 1/2" to 2")
K2	without flow straightener (for measuring section 1/4")

Accuracy class	
L1	± 1.5% of m.v. ± 0.3% of f.s.
L2	± 6% of m.v. ± 0.5% of f.s.
L3	± 1% of m.v. ± 0.3% of f.s.
Maximum pressure	
M1	16 bar (232 psi)
Surface condition	
N1	standard version
Special measuring range	
R1	Special measuring range (please specify when placing order)

### Order no. VA 525

DESCRIPTION	ORDER NO.
Compact inline flow meter	0695 5250 + Order code A...R_

### TECHNICAL DATA VA 525

<b>Parameters:</b>	m <sup>3</sup> /h, CFM (1000 mbar, 20 °C) in case of compressed air or Nm <sup>3</sup> /h, NI/min (1013 mbar, 0 °C) in case of gases
<b>Units adjustable via keys at display:</b>	m <sup>3</sup> /h, m <sup>3</sup> /min, CFM, l/s, ft/min, cfm, m/s, kg/h, kg/min, g/s, lb/min, lb/h
<b>Sensor:</b>	Thermal mass flow sensor
<b>Measured medium:</b>	Air, Argon, Nitrogen
<b>Measuring range:</b>	See table above
<b>Accuracy: (o. M. V. = of measured value) (o. F. S. = of full scale)</b>	± 1.5% of m.v. ± 0.3 % of f.s. on request: ± 1% of m.v. ± 0.3% of f.s. or ± 6% of m.v. ± 0.5% of f.s.
<b>Pressure measurement:</b>	0...232 psi, accuracy: 1%, or 0.15...29 psi (abs)
<b>Operating temperature:</b>	-4...140 °F
<b>Operating pressure:</b>	Up to 232 psi
<b>Digital output:</b>	RS 485 interface, (Modbus-RTU), M-Bus (optional) Ethernet interface or PoE
<b>Analog output:</b>	4...20 mA
<b>Pulse output:</b>	1 pulse per CF or per litre electrically isolated. Pulse weight can be set on the display. Alternatively, the pulse output can be used as an alarm relay.
<b>Supply:</b>	18...36 VDC, 5 W
<b>Burden:</b>	< 500 Ω
<b>Housing:</b>	Polycarbonate (IP 65)
<b>Measuring section:</b>	Aluminum
<b>Connection thread of measuring sections:</b>	G 1/2" to G 2" or NPT 1/2" to NPT 2"
<b>Mounting position:</b>	any