



VD 520 - Inline differential pressure flow sensor

FIELD OF APPLICATION:

- Wet compressed air
- Technical gases
- Mixed gases: e. g. Natural gas/H₂
- LPG
- Propane
- CO₂

Benefits at a glance:

- Ready-to-use compact flow meter to minimize installation effort.
- Pressure and temperature compensation integrated
- Provides flow rate, total consumption, temperature and pressure
- Differential pressure sensor element with unique sensitivity, measures highly accurate at < 2 m/s
- Large flow range with extended turn down ratio thanks to the use of measuring sections with reduced inner diameter
- Shorter inlet sections required due to the use of an averaging pitot tube
- Robust design, no moving parts
- Sensor head can be removed for calibration purposes

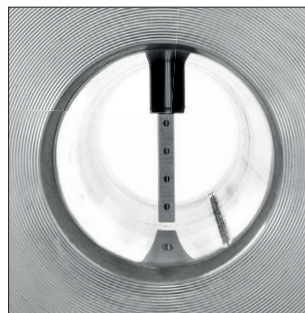
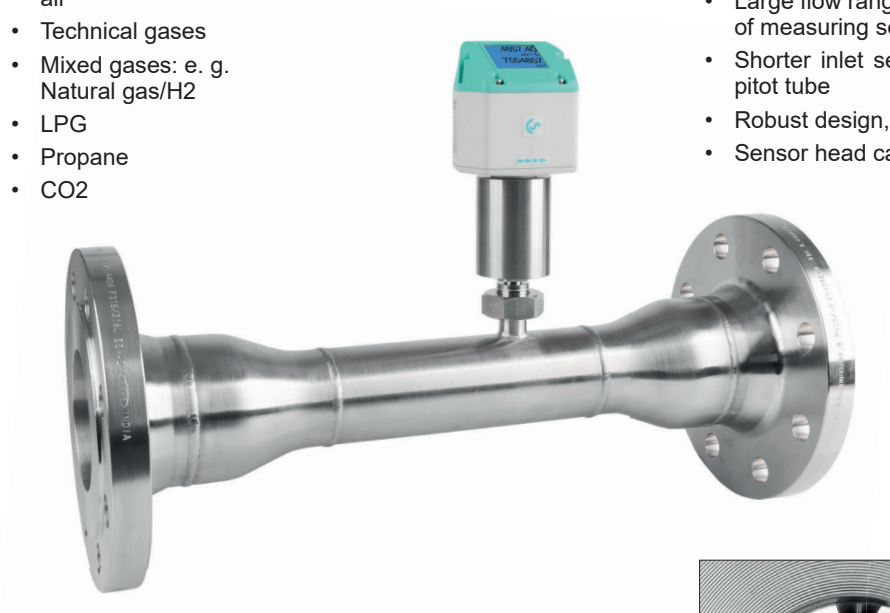

Averaging pitot tube

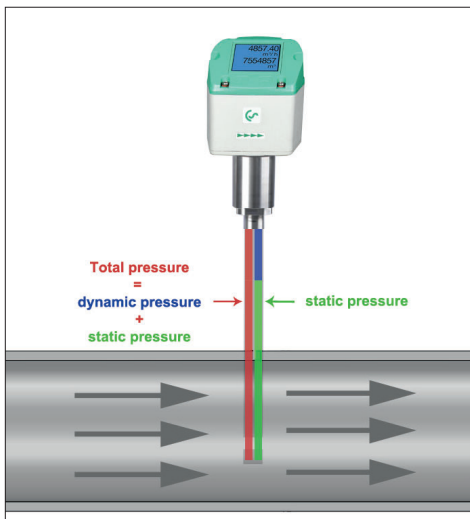

The integrated, precise differential pressure sensor measures the differential pressure/dynamic pressure at the sensor tip. The pressure depends on the respective gas velocity. The flow is therefore easy to determine with the pipe diameter.

The additional measurement of temperature and absolute pressure and calculation of the relevant density means that measuring can be carried out for various gases, a wide variety of temperatures and pressures.

TECHNICAL DATA VD 520

Measuring range:	2 up to 224 m/s / 600 m/s (compressed air) 0.04 up to 500 mbar differential pressure for gases
Measured medium:	Air and gases
Accuracy: (m.v.: of meas. value)	± 1.5% of m.v.
Measuring principle:	Differential pressure
Measuring span:	1 : 100 / 1 : 300
Response time:	t ₉₉ : < 1 sec.
Temperature of the medium:	-22 °...+176 °F
Operating pressure:	-14.5...435 psi (g)
Ambient temperature:	-4 °...+158 °F
Power supply:	18...36 VDC, 5 W
Signal outputs:	As standard: RS 485 (Modbus-RTU), 4...20 mA, pulse Optional: Ethernet Interface (PoE), M-Bus



Example order code VD 520:

0690 0520_A1_C1_D1_E1_F2_G1_H1_K1_L1

Measuring section	
A1	DN 15
A2	DN 20
A3	DN 25
A23	DN 25 reduced DN 15 (only with Flange)
A4	DN 32
A24	DN 32 reduced DN 20 (only with Flange)
A5	DN 40
A25	DN 40 reduced DN 25 (only with Flange)
A6	DN 50
A26	DN 50 reduced DN 32 (only with Flange)
A7	DN 65 (only with Flange)
A27	DN 65 reduced DN 40 (only with Flange)
A8	DN 80 (only with Flange)
A28	DN 80 reduced DN 50 (only with Flange)
A29	DN 100 reduced DN 65 (only with Flange)

Measuring range	
B1	224 m/s (compressed air)
B2	600 m/s (compressed air)
B3	0.04 - 500 mbar differential pressure (gases)

Process connection	
C1	R male thread
C2	NPT male thread
C3	Flange DIN EN 1092-1
C4	Flange ANSI 16.5 Class 150 lbs
C5	Flange ANSI 16.5 Class 300 lbs

Display	
D1	with integrated display

Signal outputs / bus connection option	
E1	1x 4...20 mA analog output (electrically not isolated), pulse output, RS 485 (Modbus-RTU)
E2	Ethernet interface (Modbus/TCP), 1 x 4...20 mA analog output (not electrically isolated), RS 485 (Modbus-RTU)
E3	Ethernet interface PoE (Power over Ethernet) (Modbus/TCP), 1 x 4...20 mA analog output (not electrically isolated), RS 485 (Modbus-RTU)
E4	M-Bus, 1 x 4...20 mA analog output (not electrically isolated), RS 485 (Modbus-RTU)

Calibration	
F1	No real gas adjustment - gas type configuration per gas constant
F2	Real gas adjustment in the gas type selected below

Gas type	
G1	Compressed air
G2	Nitrogen (N2)
G3	Argon (Ar)
G4	Carbon dioxide (CO2)
G5	Oxygen (O2)
G6	Nitrous oxide (N2O)
G7	Natural gas (NG)
G8	Helium (He)
G9	Propane (C3H8)
G10	Methane (CH4)
G11	Biogas (Methane 50%: CO2 50%)
G12	Hydrogen (H2)
G90	Further gas / please indicate gas type (on request)
G91	Gas mixture / please indicate mixture ratio (on request)

Reference standard	
H1	20 °C, 1000 mbar
H2	0 °C, 1013.25 mbar
H3	15 °C, 981 mbar
H4	15 °C, 1013.25 mbar

Maximum pressure	
K1	30 bar (435 psi)
K3	2 bar (29 psi)
K4	10 bar (145 psi)

Surface condition	
L1	standard version
L2	Special cleaning - oil and grease free (e. g. for oxygen applications and so on)
L3	Silicone-free version including special cleaning oil- and grease-free

DESCRIPTION	ORDER NO.
VD 520 Inline differential pressure flow sensor	0690 0520 + Order code A...L_
Accessories:	
ISO calibration certificate (5 calibration points) for VA sensors	3200 0001
Certificate of origin	Z695 5012
Closing cap for measuring section in aluminum	0190 0001
Closing cap for measuring section stainless steel 1.4404	0190 0002
Connection cable for VA/FA series, 16 ft.	0553 0104
Connection cable for VA/FA series, 32 ft.	0553 0105
Ethernet connection cable length 16 ft., M12 plug x-coded (8 pin) to RJ 45 plug	0553 2503
Ethernet connection cable length 32 ft., M12 plug x-coded (8 pin) to RJ 45 plug	0553 2504

Flow measuring ranges VD 520 for compressed air (ISO 1217:1000 mbar, 20 °C [68 °F])

Inside diameter of pipe		VD 520 2 ... 224 m/s		
		Measuring range initial values and full scale		
Inch	mm	DN	m³/h	cfm
1/2"	16.1	DN 15	1 ... 110	0.6 ... 65
3/4"	21.7	DN 20	2 ... 215	1.2 ... 127
1"	27.3	DN 25	3.2 ... 357	1.9 ... 210
1 1/4"	36.0	DN 32	5.7 ... 644	3.4 ... 379
1 1/2"	41.9	DN 40	8 ... 886	4.7... 522
2"	53.1	DN 50	13 ... 1450	8 ... 853
2 1/2"	68.9	DN 65	23 ... 2484	13 ... 1462
3"	80.9	DN 80	31 ... 3440	18 ... 2025



Flow [Differential pressure]

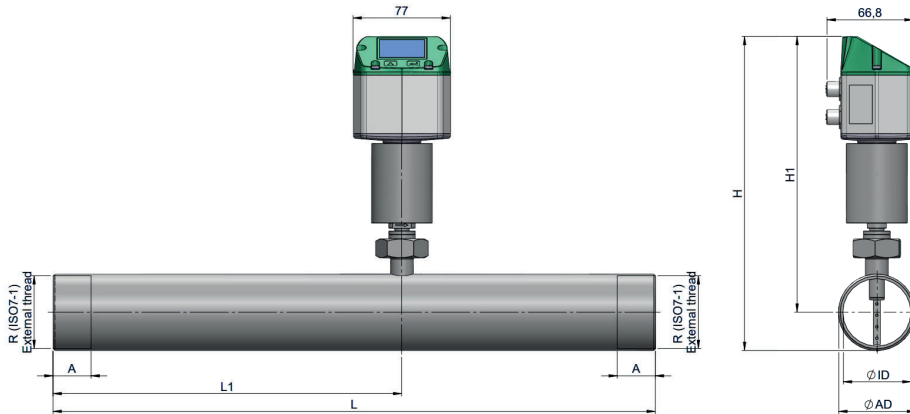

VD 520- with thread

Measuring section	AD pipe - mm	ID pipe - mm	L - mm	L1 - mm	H - mm	H1 - mm	R	A - mm
DN 15	21.3	16.1	300	210	227.9	217.2	R 1/2"	20
DN 20	26.9	21.7	475	275	230.7	217.2	R 3/4"	20
DN 25	33.7	27.3	475	275	234.1	217.2	R 1"	25
DN 32	42.4	36.0	475	275	238.4	217.2	R 1 1/4"	25
DN 40	48.3	41.9	475	275	241.4	217.2	R 1 1/2"	25
DN 50	60.3	53.1	475	275	247.4	217.2	R 2"	30

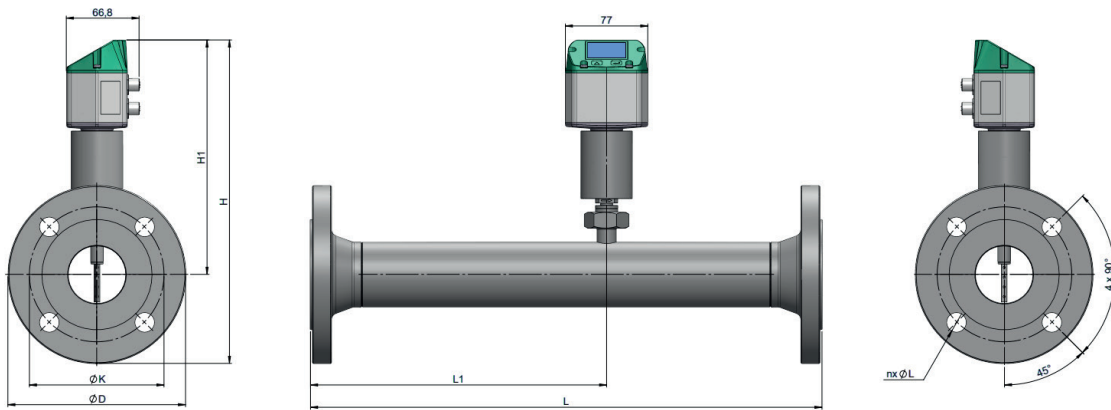

VD 520 - with flange (Material stainless steel: 1.4404)

Measuring section	AD pipe - mm	ID pipe - mm	L - mm	L1 - mm	H - mm	H1 ges - mm	ϕD - mm	ϕK - mm	n x ϕL - mm
DN 15	21.3	16.1	300	210	264.7	217.2	95	65	4x14
DN 20	26.9	21.7	475	275	269.7	217.2	105	75	4x14
DN 25	33.7	27.3	475	275	274.7	217.2	115	85	4x14
DN 32	42.4	36.0	475	275	287.2	217.2	140	100	4x18
DN 40	48.3	41.9	475	275	292.2	217.2	150	110	4x18
DN 50	60.3	53.1	475	275	299.7	217.2	165	125	4x18
DN 65	76.1	68.9	475	275	319.7	217.2	185	145	8x18
DN 80	88.9	80.9	475	275	327.2	217.2	200	160	8x18

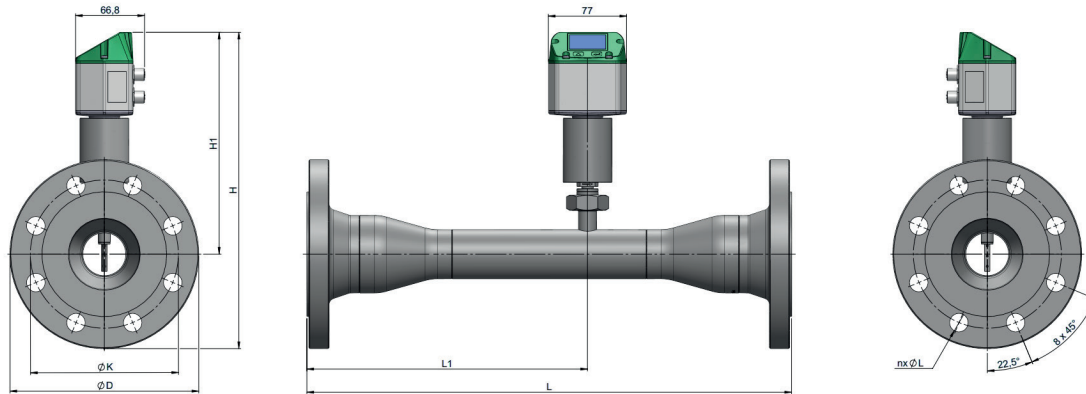

VD 520 - Reduced measuring section with flange (Material stainless steel: 1.4404)								Flange DIN EN 1092-1		
Measuring section	Reduction	AD pipe - mm	ID pipe - mm	L - mm	L1 - mm	H - mm	H1 - mm	Ø D - mm	Ø K - mm	n x Ø L - mm
DN 25	DN 25 - DN 15	21.3	16.1	475	275	274.7	217.2	115	85	4x14
DN 32	DN 32 - DN 20	26.9	21.7	475	275	287.2	217.2	140	100	4x18
DN 40	DN 40 - DN 25	33.7	27.3	475	275	292.2	217.2	150	110	4x18
DN 50	DN 50 - DN 32	42.4	36.0	475	275	299.7	217.2	165	125	4x18
DN 65	DN 65 - DN 40	48.3	41.9	475	275	309.7	217.2	185	145	8x18
DN 80	DN 80 - DN 50	60.3	53.1	475	275	317.2	217.2	200	160	8x18
DN 100	DN 100 - DN 65	76.1	68.9	475	275	344.7	227.2	235	190	8x22