



## VU 570 - Vortex ultrasonic flow sensor for technical gases and mixed gases

Independent from gas composition – integrated pressure and temperature compensation – larger measuring range than common Vortex sensors

### FIELD OF APPLICATION:

- Technical gases
- Mixed gases
- Compressed air in PET bottles production
- LPG
- Propane
- Crypton



### Function principle Vortex ultrasonic:

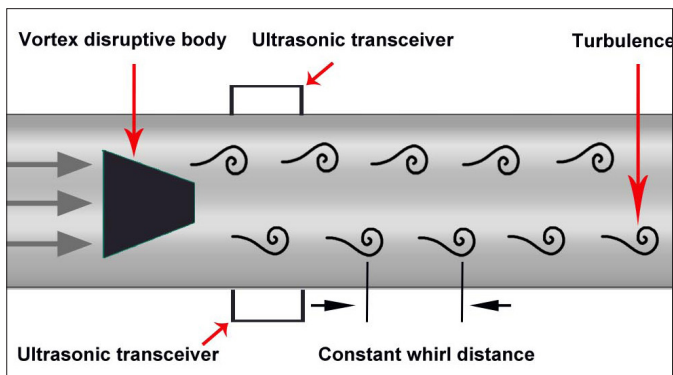

### Benefits at a glance:

- Measurement of standard volume flow, operating volume flow, and mass flow
- Suitable for unknown/changing gas compositions and mixed gases
- The innovative measuring principle grants a precise flow measurement in different gases
- Suitable for quick temperature and pressure changes as well as high mass flows

### Advantages towards common mechanic gas meters:

- No moving parts – no wear

### Advantages towards common Vortex sensors:

- Precise measurement already from 0.3 m/s (59 fpm)



Example order code VU 570: 0697 0570\_A1\_B1\_C1\_D1\_E1\_F1\_G1\_H1

### Measuring section

A1	1/2" (DN 15)
A2	3/4" (DN 20)
A3	1" (DN 25)
A4	1 1/4" (DN 32)
A5	1 1/2" (DN 40)
A6	2" (DN 50)
A7	2 1/2" (DN 65). (only in flanged version)
A8	3" (DN 80). (only in flanged version)

### Process connection

B1	R outer threads
B2	NPT outer threads
B3	Flange DIN 1092-1
B4	Flange ANSI 16.5 Class 150 lbs
B5	Flange ANSI 16.5 Class 300 lbs

### Option display

C1	With integrated display
C2	Without display

### Pressure sensor

D1	16 bar (g) (232 psi)
D2	40 bar (g) (580 psi)
D3	1.5 bar (g) (22 psi)

### Signal outputs / bus connection option

E1	2 x 4...20 mA analog output (galv. isolated). pulse output. RS 485 (Modbus-RTU)
E4	1 x 4...20 mA analog output (galv. not isolated). pulse output RS 485 (Modbus-RTU)
E5	Ethernet-Interface (Modbus/TCP). 1 x 4...20 mA analog output (galv. not isolated). pulse output. RS 485 (Modbus-RTU)
E8	M-Bus. 1 x 4...20 mA analog output (galv. not isolated). pulse output RS 485 (Modbus-RTU)
E9	Ethernet-Interface PoE (Power over Ethernet) Modbus/TCP. 1 x 4...20 mA analog output (galv. not isolated). pulse output. RS 485 (Modbus-RTU)

### Calibration

F1	No real gas calibration - Adjustment of gas type via gas constant
F2	Real gas calibration in selected gas type

### Reference conditions

G1	20 °C, 1000 mbar, (68 °F, 14.5 psi)
G2	0 °C, 1013.25 mbar, (32 °F, 15 psi)
G3	15 °C, 981 mbar, (59 °F, 14 psi)
G4	15 °C, 1013.25 mbar, (59 °F, 15 psi)
G5	Operation conditions

### Accuracy class

H1	± 1.5% of measured value (volume flow)
H2	± 1% of measured value (volume flow)

### TECHNICAL DATA VU 570

<b>Measuring range:</b>	See table
<b>Measuring medium:</b>	Air, non-aggressive gases and mixed gases (non-condensing)
<b>Accuracy:</b>	± 1.5 % m. v., optional
<b>Volume flow (m³/h)</b>	± 1 % m. v.
<b>Mass flow (kg/h) resp. Standard volume flow (Nm³/h)</b>	± 2 % m. v., optional ± 1.5 % m. v.
<b>Meas. principle:</b>	Vortex ultrasonic – Vortex frequency measurement
<b>Process temp.:</b>	-40°...+100°C, (-40°F...212 °F)
<b>Process pressure:</b>	Up to 40 bar, (580 psi overpressure)
<b>Protection class:</b>	IP67
<b>Material meas. Section and medium-touching parts:</b>	Stainless steel 316, Plastic
<b>Material display unit:</b>	Aluminum - Die casting
<b>Signal outputs:</b>	As a standard: RS 485 (Modbus-RTU), 1x 4...20 mA, pulse Optional: Ethernet Interface
<b>Power supply :</b>	18...36 VDC
<b>Measuring span:</b>	1:50
<b>Repeatability:</b>	± 0.3 % v. M.
<b>Process connection:</b>	Flange DIN EN1092-1 or Flange ANSI 150 lbs - 300 lbs R 1/2" - R 2" (BSP British Standard Piping) 1/2" - 2" NPT-thread

### DESCRIPTION ORDER NO.

VU 570 - Vortex ultrasonic flow sensor for technical gases and mixed gases	0697 0570+ Order code A...H_
<b>Further accessories:</b> ISO - calibration certificate at 5 measuring points	3200 0001

### Measuring ranges for gases VU 570 under operation conditions

Inch	mm	DN	m/s		m³/h		cfm	
			from	to	from	to	from	to
1/2"	16.1	15	0.5	25	0.4	22.0	0.2	12.9
3/4"	21.7	20			0.7	39.9	0.4	23.5
1"	27.3	25			0.6	63.2	0.4	37.2
1 1/4"	36	32	0.3	25	1.1	109.9	0.6	64.7
1 1/2"	41.9	40			1.5	148.9	0.9	87.6
2"	53.1	50			2.4	239.2	1.4	140.8
2 1/2"	68.9	65			4.0	402.7	2.4	237.0
3"	80.9	80			5.6	555.2	3.3	326.7

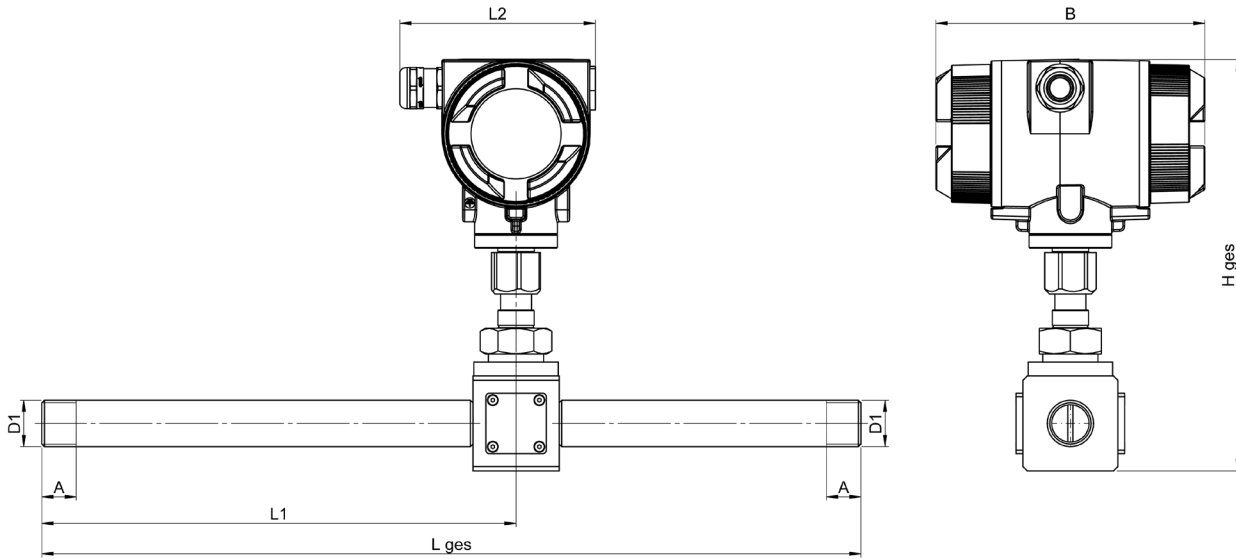

### VU 570 - with thread

Connection thread	AD pipe - mm	ID pipe - mm	L ges - mm	L1 - mm	L2 - mm	H ges - mm	B - mm	A - mm
R 1/2"	21.3	16.1	300	210	113.4	238	156	20
R 3/4"	26.9	21.7	475	275	113.4	238	156	20
R1"	33.7	27.3	475	275	113.4	253	156	25
R1 1/4"	42.4	36.0	475	275	113.4	253	156	25
R1 1/2"	48.3	41.9	475	275	113.4	260	156	25
R2"	60.3	53.1	475	275	113.4	271	156	30

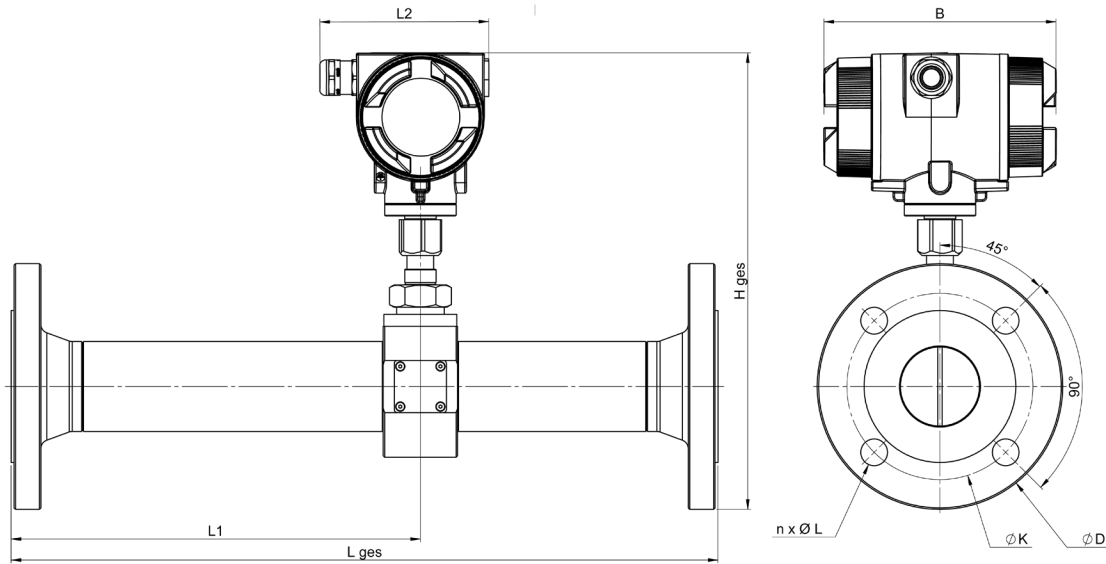

### VU 570 - with flanges

Pipe	AD pipe - mm	ID pipe - mm	L ges - mm	L1 - mm	L2 - mm	H ges - mm	B - mm	Ø D	Ø K	n x Ø L
DN 15	21.3	16.1	300	210	113.4	258.5	156	95	65	4x14
DN 20	26.9	21.7	475	275	113.4	263.5	156	105	75	4x14
DN 25	33.7	27.3	475	275	113.4	276	156	115	85	4x14
DN 32	42.4	36.0	475	275	113.4	288.5	156	140	100	4x18
DN 40	48.3	41.9	475	275	113.4	293	156	150	110	4x18
DN 50	60.3	53.1	475	275	113.4	306.5	156	165	125	4x18
DN 65	76.1	68.9	475	275	113.4	325	156	185	145	8x18
DN 80	88.9	80.9	475	275	113.4	339	156	200	160	8x18